



**Mastertech**  
**7120GFS**

型式名 7120G-2A

# クローラクレーン

**最大定格総荷重120t×5.0m**

▶ 主要諸元	1
▶ フック巻上限界	1
▶ 仕様とアタッチメント	1

## クローラクレーン

▶ 全体図	2
▶ ブーム構成	3
▶ 作動範囲図	4
▶ 定格総荷重	5
▶ 主ブーム / 補助シーブ定格総荷重表 (59.1t カウンタウエイト)	6~9
▶ 主ブーム / 補助シーブ定格総荷重表 (53.1t カウンタウエイト [ オプション ])	10~13
▶ 主ブーム / 補助シーブ定格総荷重表 (29.1t カウンタウエイト [ オプション ])	14~17
▶ サードドラム (オプション)	18
▶ 主ブーム定格総荷重表・サードドラム使用 (59.1t カウンタウエイト)	18, 19
▶ 主ブーム定格総荷重表・サードドラム使用 (53.1t カウンタウエイト [ オプション ])	20, 21
▶ 主ブーム定格総荷重表・サードドラム使用 (29.1t カウンタウエイト [ オプション ])	21, 22

## アタッチメント(オプション)

▶ クラムシェル (59.1t カウンタウエイト)	23
---------------------------	----

## 台船搭載(オプション)

▶ 主ブーム / クラムシェル作業定格総荷重表 (53.1t カウンタウエイト)	24
▶ 分解時の寸法・質量	25~31
▶ 標準装備品 / オプション装備品	32

▶ **主要諸元 (型式：7120G-2A) FS 仕様**

項目		仕様	クローラクレーン	
形式			全旋回型クローラ式	
最大定格総荷重×作業半径		t×m	120×5.0	
ブーム長さ	基本ブーム	m	15.2	
	最長ブーム	m	61.0	
	サードドラム使用時最長ブーム	m	61.0	
作業速度(ワイヤロープ)	主, 補 巻上速度	m/min	110～3	ワイヤロープ径 φ30mm
	主, 補 巻下速度	m/min	110～3	
	ブーム 巻上速度	m/min	48～3	ワイヤロープ径 φ20mm
	ブーム 巻下速度	m/min	48～3	
	サード 巻上速度(オプション)	m/min	110～3	ワイヤロープ径 φ26mm
	サード 巻下速度(オプション)	m/min	110～3	
	旋回速度	min <sup>-1</sup> {rpm}	2.1{2.1}	
走行速度	km/h	1.3/0.9		
登坂能力	% (度)	30 (16.7)		
作業時質量(基本ブーム+120tフック付)	t	約141		
平均接地圧(基本ブーム+120tフック付)	kPa{kgf/cm <sup>2</sup> }	110 {1.12}		
原動機	エンジン名称	ISUZU 6UZ1		
	エンジン出力	kW/min <sup>-1</sup>	270/2,000	

サードドラムはオプションです。  
 上記に記載されているワイヤロープ速度は、ドラム一層目での値です。  
 また、各速度は負荷によって変化します。  
 単位は国際単位系のS I単位で、{ }内は従来表示です。

▶ **仕様とアタッチメント (クローラクレーン)**

アタッチメント	仕様	クローラクレーン
4.6m上部ブーム		◎
3.0m中間テーパーブーム*1		◎
7.6m下部ブーム		◎
3.0m中間ブーム(ケーブルローラ付)		○
6.1m中間ブーム(ケーブルローラ付)		○
9.1m中間ブーム(ケーブルローラ付)		○
120tフック(5枚シーブ)		◎
70tフック(3枚シーブ)		○
50tフック(3枚シーブ)		○
35tフック(1枚シーブ)		○
ボールフック		○
軽量フック(スイベル付)		○
2枚補助シーブ		○
主巻ワイヤロープ(φ30×200m)		◎
補巻ワイヤロープ(φ30×130m)		○
ブーム起伏ワイヤロープ(φ20×190m)		◎

◎印は標準仕様、○印はオプション設定を示します。  
 \*1 クローラクレーンの上部ブームとセットで使用します。

▶ **フック巻上限界 (単位：m)**

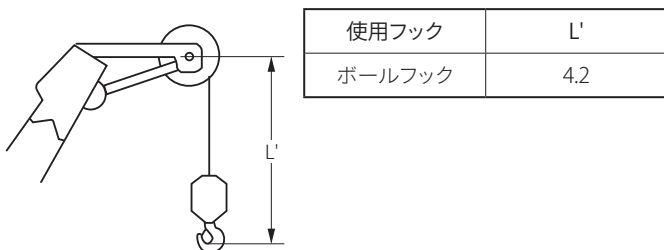
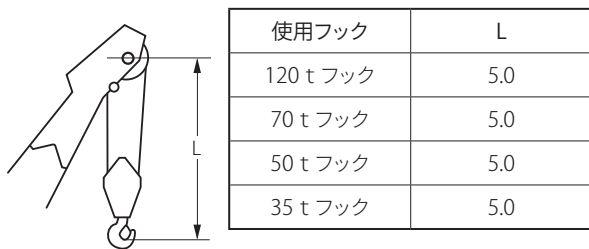





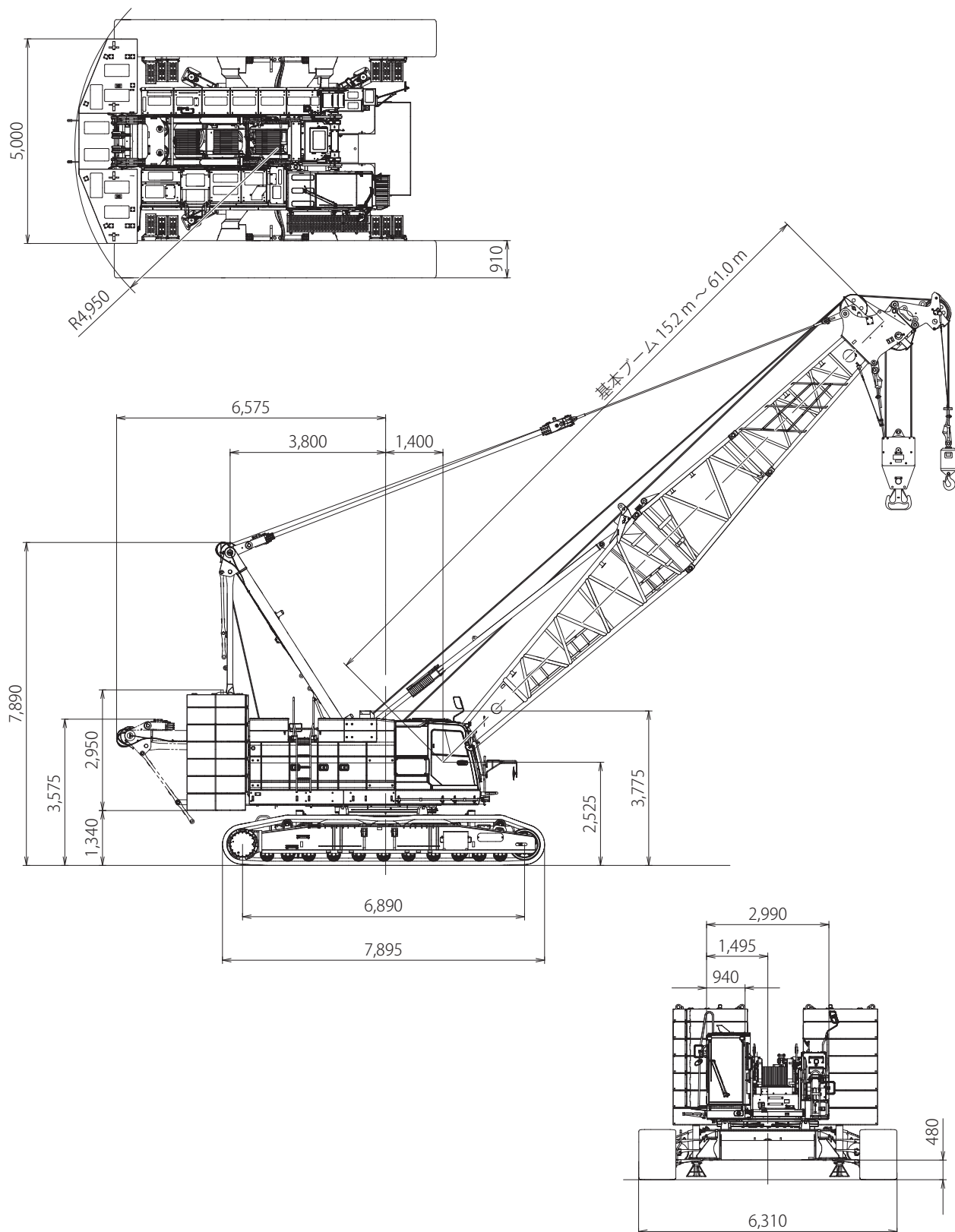

# クローラクレーン







▶ 全体図 (単位: mm)





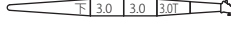
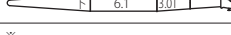
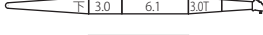
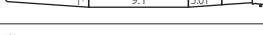
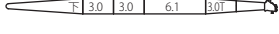
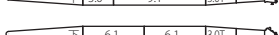
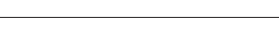
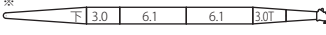
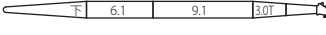
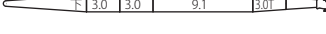

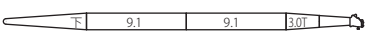
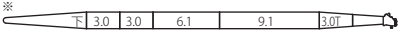
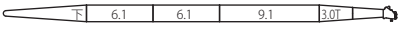

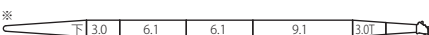
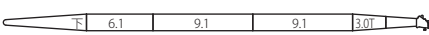
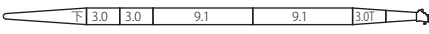

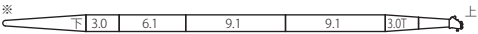
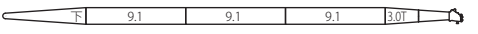
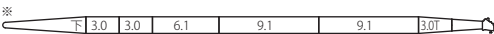
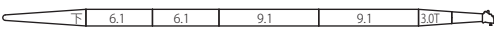
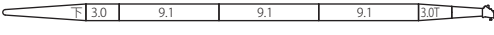
## ▶ ブーム構成

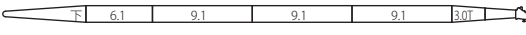
- ※印は、これより短いブームの組立可能な構成を示します。
- 使用するガイラインの径はφ 30mm です。

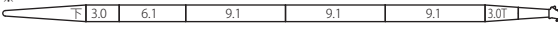
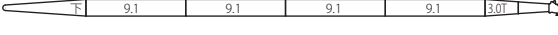
記号	ブーム長さ	備考
	7.6m	下部ブーム
	3.0m	ブーム
	6.1m	ブーム
	9.1m	ブーム
	3.0m	テーパブーム
	4.6m	上部ブーム

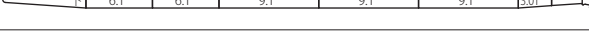
ブーム長さ m (ft.)	ブーム構成
15.2 (50)	
18.3 (60)	※ 
21.3 (70)	※  ※ 
24.4 (80)	※  ※ 
27.4 (90)	※  ※  ※ 
30.5 (100)	※  ※  ※ 
33.5 (110)	※  ※ 
36.6 (120)	※  ※  ※ 
39.6 (130)	※  ※  ※ 

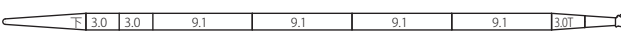
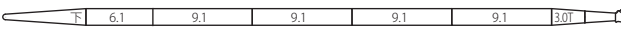
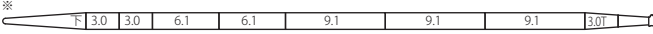
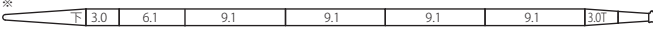
ブーム長さ m (ft.)	ブーム構成
42.7 (140)	※  ※ 
45.7 (150)	※  ※  ※ 
48.8 (160)	※  ※  ※ 
51.8 (170)	※  ※ 
54.9 (180)	※  ※  ※ 
57.9 (190)	※  ※  ※ 
61.0 (200)	※  ※ 

▶ 作動範囲図

▶ 主ブーム

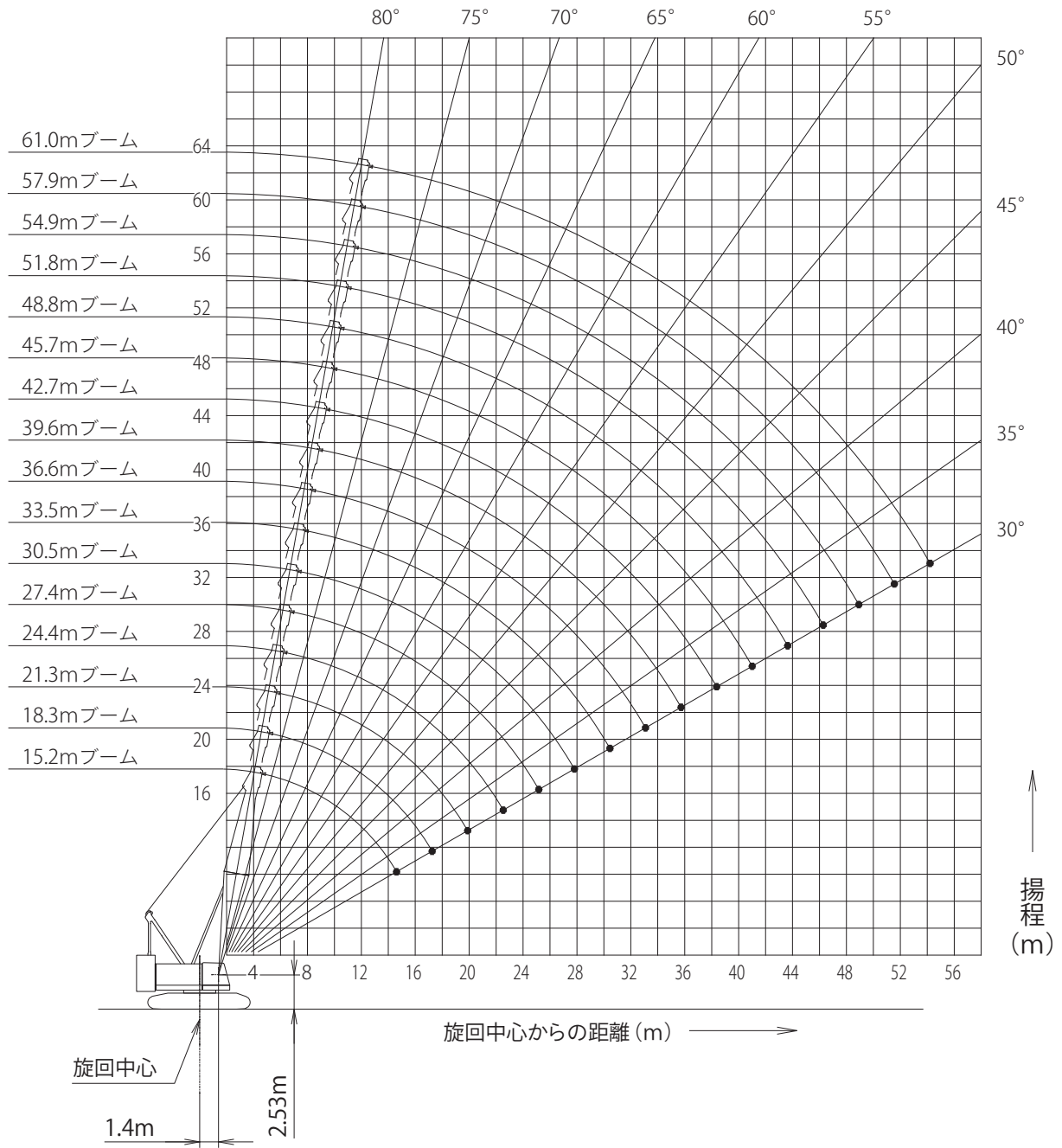

## ▶ 定格総荷重

- 定格総荷重とは、水平堅土上における転倒荷重の78%以内で、フックブロック、玉掛用ワイヤロープ等のつり具の質量を含んだ値です。
- 作業半径とはクレーン旋回中心よりつり上荷重の重心までの水平距離を意味します。
- 実際につり上げ得る荷重は定格総荷重から（フック＋玉掛用ワイヤロープ等のつり具）の質量を差し引いた値になります。
- 定格総荷重をつる場合にも風の影響、地盤の状態、作業速度その他安全作業に有害な状況がある時はオペレータは荷重の軽減、作業速度を遅くするなど状況に応じた判断をする責任があります。
- 表中の空欄の個所では作業を行うことができません。
- クレーン作業中には必ずガントリを最高位置に立ててください。

- すべてのブーム長さにおける中間ブームの構成は取扱説明書の指示を厳守してください。
- 補助シーブを装着できる主ブーム長さは、15.2m (50) ～ 61.0m (200) です。
- ⚠ 操作ミスなどによるつり荷の落下を防ぐため、クレーン作業では自由降下（フリーフォール）作業は行わないでください。

- 巻上げロープ巻掛本数に対する最大巻上荷重とフックの質量

フック呼称	最大巻上荷重 (t)									フック質量
	1本掛	2本掛	3本掛	4本掛	5本掛	6本掛	7本掛	8本掛	9本掛	
120t	—	—	—	56.0	70.0	84.0	98.0	112.0	120.0	1.80t
70t (両カギ)	—	28.0	42.0	56.0	70.0	—	—	—	—	1.20t
70t (片カギ)	—	28.0	42.0	56.0	70.0	—	—	—	—	0.93t
50t	—	28.0	42.0	50.0	—	—	—	—	—	0.85t
35t	—	28.0	35.0	—	—	—	—	—	—	0.70t
ボールフック	15.5	—	—	—	—	—	—	—	—	0.45t
スィベル付軽量フック	15.5	—	—	—	—	—	—	—	—	0.19t

フックは120t、70t、50t、35t、15.5t（ボールフック、スィベル付軽量フック）とします。

### 【カウンタウエイト減量時】

（カーボディウエイト無し）

- 自立可能な最長ブーム長さは、カウンタウエイト段数6段（最上段から1段減量）で61.0m、3段（最上段から4段減量）で57.9mです。
- 補助シーブを装着できる主ブーム長さは、カウンタウエイト段数6段（最上段から1段減量）で15.2m～61.0m、3段（最上段から4段減量）で15.2m～57.9mです。

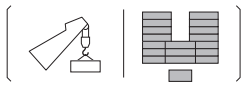

### 主ブーム定格総荷重表 (59.1tカウンタウエイト / 補助シーブなし)

(単位：t)

作業半径 (m)	ブーム長さ (m)															作業半径 (m)	
	15.2	18.3	21.3	24.4	27.4	30.5	33.5	36.6	39.6	42.7	45.7	48.8	51.8	54.9	57.9		61.0
4.5	120.0																4.5
5.0	120.0	112.0/5.1m	98.0/5.6m														5.0
6.0	110.4	110.1	98.0	84.0/6.1m	70.0/6.7m												6.0
7.0	95.1	94.8	93.3	84.0	70.0	70.0/7.2m	56.0/7.7m										7.0
8.0	79.6	79.9	79.1	77.4	70.0	70.0	56.0	56.0/8.2m	42.0/8.8m								8.0
9.0	67.7	68.5	68.4	67.2	66.0	64.9	56.0	56.0	42.0	42.0/9.3m	42.0/9.8m						9.0
10.0	58.3	58.8	58.6	58.6	58.3	57.4	56.0	55.0	42.0	42.0	42.0	28.0/10.4m	28.0/10.9m	28.0/11.4m			10.0
12.0	44.2	45.5	45.3	45.3	45.1	45.0	45.0	44.8	42.0	42.0	42.0	28.0	28.0	28.0	28.0	28.0/12.5m	12.0
14.0	33.3	37.0	36.8	36.7	36.5	36.4	36.4	36.1	36.1	36.0	35.6	28.0	28.0	28.0	28.0	27.2	14.0
16.0	29.1/14.9m	29.8	30.8	30.7	30.6	30.4	30.3	30.1	30.1	29.9	29.7	28.0	28.0	28.0	27.6	25.6	16.0
18.0		24.6/17.5m	26.4	26.3	26.1	26.0	25.9	25.7	25.7	25.5	25.3	25.3	25.1	24.9	24.7	23.9	18.0
20.0			21.3	22.9	22.7	22.6	22.5	22.3	22.2	22.1	21.9	21.7	21.7	21.5	21.3	21.1	20.0
22.0			21.0/20.1m	19.7	20.0	19.9	19.8	19.6	19.5	19.4	19.1	19.0	18.9	18.7	18.6	18.4	22.0
24.0				18.2/22.8m	17.9	17.7	17.6	17.4	17.3	17.2	16.9	16.8	16.7	16.5	16.4	16.2	24.0
26.0					15.8/25.4m	16.0	15.8	15.6	15.5	15.3	15.1	15.0	14.9	14.7	14.5	14.3	26.0
28.0						13.9	14.3	14.1	14.0	13.8	13.6	13.5	13.4	13.2	13.0	12.8	28.0
30.0							12.9	12.8	12.7	12.5	12.3	12.2	12.1	11.9	11.7	11.5	30.0
32.0							12.2/30.7m	11.7	11.6	11.4	11.2	11.0	10.9	10.7	10.6	10.3	32.0
34.0								10.7/33.3m	10.6	10.4	10.2	10.1	10.0	9.7	9.6	9.3	34.0
36.0									9.4	9.6	9.3	9.2	9.1	8.9	8.7	8.5	36.0
38.0										8.7	8.6	8.4	8.3	8.1	7.9	7.7	38.0
40.0										8.3/38.6m	7.8	7.8	7.7	7.4	7.3	7.0	40.0
42.0											7.2/41.2m	7.1	7.1	6.8	6.6	6.4	42.0
44.0												6.2/43.9m	6.4	6.3	6.1	5.9	44.0
46.0													5.6	5.7	5.6	5.3	46.0
48.0													5.4/46.5m	5.0	5.0	4.8	48.0
50.0														4.5/49.2m	4.4	4.3	50.0
52.0															3.8/51.8m	3.8	52.0
54.0																3.2	54.0
56.0																3.0/54.4m	56.0

※表中の太線で囲まれた部分は、ブーム等の強度によって定められた値です。

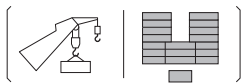

### 主ブーム定格総荷重表 (59.1tカウンタウエイト / 1枚または2枚補助シーブ付き / 軽量フック付き)

(単位：t)

作業半径 (m)	ブーム長さ (m)															作業半径 (m)	
	15.2	18.3	21.3	24.4	27.4	30.5	33.5	36.6	39.6	42.7	45.7	48.8	51.8	54.9	57.9		61.0
4.5	118.8																4.5
5.0	118.8	110.8/5.1m	96.8/5.6m														5.0
6.0	109.2	108.9	96.8	82.8/6.1m	68.8/6.7m												6.0
7.0	93.9	93.6	92.1	82.8	68.8	68.8/7.2m	54.8/7.7m										7.0
8.0	78.4	78.7	77.9	76.2	68.8	68.8	54.8	54.8/8.2m	40.8/8.8m								8.0
9.0	66.5	67.3	67.2	66.0	64.8	63.7	54.8	54.8	40.8	40.8/9.3m	40.8/9.8m						9.0
10.0	57.1	57.6	57.4	57.4	57.1	56.2	54.8	53.8	40.8	40.8	40.8	26.8/10.4m	26.8/10.9m	26.8/11.4m			10.0
12.0	43.0	44.3	44.1	44.1	43.9	43.8	43.8	43.6	40.8	40.8	40.8	26.8	26.8	26.8	26.8	26.8/12.5m	12.0
14.0	32.1	35.8	35.6	35.5	35.3	35.2	35.2	34.9	34.9	34.8	34.4	26.8	26.8	26.8	26.8	26.0	14.0
16.0	27.9/14.9m	28.6	29.6	29.5	29.4	29.2	29.1	28.9	28.9	28.7	28.5	26.8	26.8	26.8	26.4	24.4	16.0
18.0		23.4/17.5m	25.2	25.1	24.9	24.8	24.7	24.5	24.5	24.3	24.1	24.1	23.9	23.7	23.5	22.7	18.0
20.0			20.1	21.7	21.5	21.4	21.3	21.1	21.0	20.9	20.7	20.5	20.5	20.3	20.1	19.9	20.0
22.0			19.8/20.1m	18.5	18.8	18.7	18.6	18.4	18.3	18.2	17.9	17.8	17.7	17.5	17.4	17.2	22.0
24.0				17.0/22.8m	16.7	16.5	16.4	16.2	16.1	16.0	15.7	15.6	15.5	15.3	15.2	15.0	24.0
26.0					14.6/25.4m	14.8	14.6	14.4	14.3	14.1	13.9	13.8	13.7	13.5	13.3	13.1	26.0
28.0						12.7	13.1	12.9	12.8	12.6	12.4	12.3	12.2	12.0	11.8	11.6	28.0
30.0							11.7	11.6	11.5	11.3	11.1	11.0	10.9	10.7	10.5	10.3	30.0
32.0							11.0/30.7m	10.5	10.4	10.2	10.0	9.8	9.7	9.5	9.4	9.1	32.0
34.0								9.5/33.3m	9.4	9.2	9.0	8.9	8.8	8.5	8.4	8.1	34.0
36.0									8.2	8.4	8.1	8.0	7.9	7.7	7.5	7.3	36.0
38.0										7.5	7.4	7.2	7.1	6.9	6.7	6.5	38.0
40.0										7.1/38.6m	6.6	6.6	6.5	6.2	6.1	5.8	40.0
42.0											6.0/41.2m	5.9	5.9	5.6	5.4	5.2	42.0
44.0												5.0/43.9m	5.2	5.1	4.9	4.7	44.0
46.0													4.4	4.5	4.4	4.1	46.0
48.0													4.2/46.5m	3.8	3.8	3.6	48.0
50.0														3.3/49.2m	3.2	3.1	50.0
52.0															2.6/51.8m	2.6	52.0
54.0																2.0	54.0

※表中の太線で囲まれた部分は、ブーム等の強度によって定められた値です。

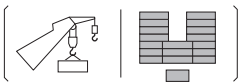

### 主ブーム定格総荷重表

(59.1tカウンタウエイト / 1枚または2枚補助シーブ付き / ボールフック付き)

(単位: t)

作業半径 (m)	ブーム長さ (m)																作業半径 (m)
	15.2	18.3	21.3	24.4	27.4	30.5	33.5	36.6	39.6	42.7	45.7	48.8	51.8	54.9	57.9	61.0	
4.5	118.5																4.5
5.0	118.5	110.5/5.1m	96.5/5.6m														5.0
6.0	108.9	108.6	96.5	82.5/6.1m	68.5/6.7m												6.0
7.0	93.6	93.3	91.8	82.5	68.5	68.5/7.2m	54.5/7.7m										7.0
8.0	78.1	78.4	77.6	75.9	68.5	68.5	54.5	54.5/8.2m	40.5/8.8m								8.0
9.0	66.2	67.0	66.9	65.7	64.5	63.4	54.5	54.5	40.5	40.5/9.3m	40.5/9.8m						9.0
10.0	56.8	57.3	57.1	57.1	56.8	55.9	54.5	53.5	40.5	40.5	40.5	26.5/10.4m	26.5/10.9m	26.5/11.4m			10.0
12.0	42.7	44.0	43.8	43.8	43.6	43.5	43.5	43.3	40.5	40.5	40.5	26.5	26.5	26.5	26.5	26.5/12.5m	12.0
14.0	31.8	35.5	35.3	35.2	35.0	34.9	34.9	34.6	34.6	34.5	34.1	26.5	26.5	26.5	26.5	25.7	14.0
16.0	27.6/14.9m	28.3	29.3	29.2	29.1	28.9	28.8	28.6	28.6	28.4	28.2	26.5	26.5	26.5	26.1	24.1	16.0
18.0		23.1/17.5m	24.9	24.8	24.6	24.5	24.4	24.2	24.2	24.0	23.8	23.8	23.6	23.4	23.2	22.4	18.0
20.0			19.8	21.4	21.2	21.1	21.0	20.8	20.7	20.6	20.4	20.2	20.2	20.0	19.8	19.6	20.0
22.0			19.5/20.1m	18.2	18.5	18.4	18.3	18.1	18.0	17.9	17.6	17.5	17.4	17.2	17.1	16.9	22.0
24.0				16.7/22.8m	16.4	16.2	16.1	15.9	15.8	15.7	15.4	15.3	15.2	15.0	14.9	14.7	24.0
26.0					14.3/25.4m	14.5	14.3	14.1	14.0	13.8	13.6	13.5	13.4	13.2	13.0	12.8	26.0
28.0						12.4	12.8	12.6	12.5	12.3	12.1	12.0	11.9	11.7	11.5	11.3	28.0
30.0							11.4	11.3	11.2	11.0	10.8	10.7	10.6	10.4	10.2	10.0	30.0
32.0							10.7/30.7m	10.2	10.1	9.9	9.7	9.5	9.4	9.2	9.1	8.8	32.0
34.0								9.2/33.3m	9.1	8.9	8.7	8.6	8.5	8.2	8.1	7.8	34.0
36.0									7.9	8.1	7.8	7.7	7.6	7.4	7.2	7.0	36.0
38.0										7.2	7.1	6.9	6.8	6.6	6.4	6.2	38.0
40.0										6.8/38.6m	6.3	6.3	6.2	5.9	5.8	5.5	40.0
42.0											5.7/41.2m	5.6	5.6	5.3	5.1	4.9	42.0
44.0												4.7/43.9m	4.9	4.8	4.6	4.4	44.0
46.0													4.1	4.2	4.1	3.8	46.0
48.0													3.9/46.5m	3.5	3.5	3.3	48.0
50.0														3.0/49.2m	2.9	2.8	50.0
52.0															2.3/51.8m	2.3	52.0

※表中の太線で囲まれた部分は、ブーム等の強度によって定められた値です。

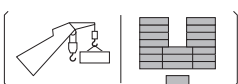

### 補助シーブ定格総荷重表

(59.1tカウンタウエイト / 120tフック装着 / 1枚または2枚補助シーブ付き)

(単位: t)

作業半径 (m)	ブーム長さ (m)																作業半径 (m)
	15.2	18.3	21.3	24.4	27.4	30.5	33.5	36.6	39.6	42.7	45.7	48.8	51.8	54.9	57.9	61.0	
5.0	15.5/5.3m	15.5/5.8m															5.0
6.0	15.5	15.5	15.5/6.3m	15.5/6.9m													6.0
7.0	15.5	15.5	15.5	15.5	15.5/7.4m	15.5/7.9m											7.0
8.0	15.5	15.5	15.5	15.5	15.5	15.5	15.5/8.4m										8.0
9.0	15.5	15.5	15.5	15.5	15.5	15.5	15.5	15.5	15.5/9.5m								9.0
10.0	15.5	15.5	15.5	15.5	15.5	15.5	15.5	15.5	15.5	15.5	15.5/10.6m	15.5/11.1m	15.5/11.6m				10.0
12.0	15.5	15.5	15.5	15.5	15.5	15.5	15.5	15.5	15.5	15.5	15.5	15.5	15.5	15.5/12.2m	15.5/12.7m	15.5/13.2m	12.0
14.0	15.5	15.5	15.5	15.5	15.5	15.5	15.5	15.5	15.5	15.5	15.5	15.5	15.5	15.5	15.5	15.5	14.0
16.0	15.5	15.5	15.5	15.5	15.5	15.5	15.5	15.5	15.5	15.5	15.5	15.5	15.5	15.5	15.5	15.5	16.0
18.0	15.5/16.2m	15.5	15.5	15.5	15.5	15.5	15.5	15.5	15.5	15.5	15.5	15.5	15.5	15.5	15.5	15.5	18.0
20.0		15.5/18.8m	15.5	15.5	15.5	15.5	15.5	15.5	15.5	15.5	15.5	15.5	15.5	15.5	15.5	15.5	20.0
22.0			15.5/21.5m	15.5	15.5	15.5	15.5	15.5	15.5	15.5	15.5	15.5	15.5	15.5	15.5	15.5	22.0
24.0				13.5	15.5	15.4	15.3	15.1	15.0	14.9	14.6	14.5	14.4	14.2	14.1	13.9	24.0
26.0				13.3/24.1m	12.6	13.7	13.5	13.3	13.2	13.0	12.8	12.7	12.6	12.4	12.2	12.0	26.0
28.0					11.5/26.7m	11.6	12.0	11.8	11.7	11.5	11.3	11.2	11.1	10.9	10.7	10.5	28.0
30.0						10.1/29.4m	10.6	10.5	10.4	10.2	10.0	9.9	9.8	9.6	9.4	9.2	30.0
32.0							8.5	9.4	9.3	9.1	8.9	8.7	8.6	8.4	8.3	8.0	32.0
34.0								7.8	8.3	8.1	7.9	7.8	7.7	7.4	7.3	7.0	34.0
36.0								7.3/34.7m	7.1	7.3	7.0	6.9	6.8	6.6	6.4	6.2	36.0
38.0									6.2/37.3m	6.4	6.3	6.1	6.0	5.8	5.6	5.4	38.0
40.0										5.1/39.9m	5.5	5.5	5.4	5.1	5.0	4.7	40.0
42.0											4.5	4.8	4.8	4.5	4.3	4.1	42.0
44.0												4.2/42.6m	3.8	4.1	4.0	3.8	44.0
46.0													3.2/45.2m	3.3	3.4	3.0	46.0
48.0														2.5/47.9m	2.7	2.7	48.0
50.0															2.1	2.0	50.0

※表中の太線で囲まれた部分は、ブーム等の強度によって定められた値です。



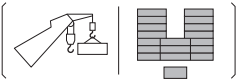

### ▶ 補助シーブ定格総荷重表

(59.1tカウンタウイト / 70tフック装着 / 1枚または2枚補助シーブ付き)

(単位：t)

作業半径 (m)	ブーム長さ (m)																作業半径 (m)	
	15.2	18.3	21.3	24.4	27.4	30.5	33.5	36.6	39.6	42.7	45.7	48.8	51.8	54.9	57.9	61.0		
5.0	15.5/5.3m	15.5/5.8m															5.0	
6.0	15.5	15.5	15.5/6.3m	15.5/6.9m													6.0	
7.0	15.5	15.5	15.5	15.5	15.5/7.4m	15.5/7.9m											7.0	
8.0	15.5	15.5	15.5	15.5	15.5	15.5	15.5/8.4m										8.0	
9.0	15.5	15.5	15.5	15.5	15.5	15.5	15.5	15.5	15.5/9.5m								9.0	
10.0	15.5	15.5	15.5	15.5	15.5	15.5	15.5	15.5	15.5	15.5	15.5	15.5/10.6m	15.5/11.1m	15.5/11.6m			10.0	
12.0	15.5	15.5	15.5	15.5	15.5	15.5	15.5	15.5	15.5	15.5	15.5	15.5	15.5	15.5	15.5/12.2m	15.5/12.7m	15.5/13.2m	12.0
14.0	15.5	15.5	15.5	15.5	15.5	15.5	15.5	15.5	15.5	15.5	15.5	15.5	15.5	15.5	15.5	15.5	15.5	14.0
16.0	15.5	15.5	15.5	15.5	15.5	15.5	15.5	15.5	15.5	15.5	15.5	15.5	15.5	15.5	15.5	15.5	15.5	16.0
18.0	15.5/16.2m	15.5	15.5	15.5	15.5	15.5	15.5	15.5	15.5	15.5	15.5	15.5	15.5	15.5	15.5	15.5	15.5	18.0
20.0		15.5/18.8m	15.5	15.5	15.5	15.5	15.5	15.5	15.5	15.5	15.5	15.5	15.5	15.5	15.5	15.5	15.5	20.0
22.0			15.5/21.5m	15.5	15.5	15.5	15.5	15.5	15.5	15.5	15.5	15.5	15.5	15.5	15.5	15.5	15.5	22.0
24.0				14.1	15.5	15.5	15.5	15.5	15.5	15.5	15.5	15.2	15.1	15.0	14.8	14.7	14.5	24.0
26.0				13.9/24.1m	13.2	14.3	14.1	13.9	13.8	13.6	13.4	13.3	13.2	13.0	12.8	12.6	12.6	26.0
28.0					12.1/26.7m	12.2	12.6	12.4	12.3	12.1	11.9	11.8	11.7	11.5	11.3	11.1	11.1	28.0
30.0						10.7/29.4m	11.2	11.1	11.0	10.8	10.6	10.5	10.4	10.2	10.0	9.8	9.8	30.0
32.0							9.1	10.0	9.9	9.7	9.5	9.3	9.2	9.0	8.9	8.6	8.6	32.0
34.0								8.4	8.9	8.7	8.5	8.4	8.3	8.0	7.9	7.6	7.6	34.0
36.0								7.9/34.7m	7.7	7.9	7.6	7.5	7.4	7.2	7.0	6.8	6.8	36.0
38.0									6.8/37.3m	7.0	6.9	6.7	6.6	6.4	6.2	6.0	6.0	38.0
40.0										5.7/39.9m	6.1	6.1	6.0	5.7	5.6	5.3	5.3	40.0
42.0											5.1	5.4	5.4	5.1	4.9	4.7	4.7	42.0
44.0											4.8/42.6m	4.4	4.7	4.6	4.4	4.2	4.2	44.0
46.0												3.8/45.2m	3.9	4.0	3.9	3.6	3.6	46.0
48.0													3.1/47.9m	3.3	3.3	3.1	3.1	48.0
50.0														2.4	2.7	2.6	2.6	50.0
52.0														2.2/50.5m	2.0	2.1	2.1	52.0

※表中の太線で囲まれた部分は、ブーム等の強度によって定められた値です。

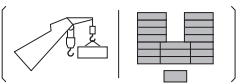

### ▶ 補助シーブ定格総荷重表

(59.1tカウンタウイト / 50tフック装着 / 1枚または2枚補助シーブ付き)

(単位：t)

作業半径 (m)	ブーム長さ (m)																作業半径 (m)	
	15.2	18.3	21.3	24.4	27.4	30.5	33.5	36.6	39.6	42.7	45.7	48.8	51.8	54.9	57.9	61.0		
5.0	15.5/5.3m	15.5/5.8m															5.0	
6.0	15.5	15.5	15.5/6.3m	15.5/6.9m													6.0	
7.0	15.5	15.5	15.5	15.5	15.5/7.4m	15.5/7.9m											7.0	
8.0	15.5	15.5	15.5	15.5	15.5	15.5	15.5/8.4m										8.0	
9.0	15.5	15.5	15.5	15.5	15.5	15.5	15.5	15.5	15.5/9.5m								9.0	
10.0	15.5	15.5	15.5	15.5	15.5	15.5	15.5	15.5	15.5	15.5	15.5	15.5/10.6m	15.5/11.1m	15.5/11.6m			10.0	
12.0	15.5	15.5	15.5	15.5	15.5	15.5	15.5	15.5	15.5	15.5	15.5	15.5	15.5	15.5	15.5/12.2m	15.5/12.7m	15.5/13.2m	12.0
14.0	15.5	15.5	15.5	15.5	15.5	15.5	15.5	15.5	15.5	15.5	15.5	15.5	15.5	15.5	15.5	15.5	15.5	14.0
16.0	15.5	15.5	15.5	15.5	15.5	15.5	15.5	15.5	15.5	15.5	15.5	15.5	15.5	15.5	15.5	15.5	15.5	16.0
18.0	15.5/16.2m	15.5	15.5	15.5	15.5	15.5	15.5	15.5	15.5	15.5	15.5	15.5	15.5	15.5	15.5	15.5	15.5	18.0
20.0		15.5/18.8m	15.5	15.5	15.5	15.5	15.5	15.5	15.5	15.5	15.5	15.5	15.5	15.5	15.5	15.5	15.5	20.0
22.0			15.5/21.5m	15.5	15.5	15.5	15.5	15.5	15.5	15.5	15.5	15.5	15.5	15.5	15.5	15.5	15.5	22.0
24.0				14.4	15.5	15.5	15.5	15.5	15.5	15.5	15.5	15.4	15.3	15.1	15.0	14.8	14.8	24.0
26.0				14.2/24.1m	13.5	14.6	14.4	14.2	14.1	13.9	13.7	13.6	13.5	13.3	13.1	12.9	12.9	26.0
28.0					12.4/26.7m	12.5	12.9	12.7	12.6	12.4	12.2	12.1	12.0	11.8	11.6	11.4	11.4	28.0
30.0						11.0/29.4m	11.5	11.4	11.3	11.1	10.9	10.8	10.7	10.5	10.3	10.1	10.1	30.0
32.0							9.4	10.3	10.2	10.0	9.8	9.6	9.5	9.3	9.2	8.9	8.9	32.0
34.0								8.7	9.2	9.0	8.8	8.7	8.6	8.3	8.2	7.9	7.9	34.0
36.0								8.2/34.7m	8.0	8.2	7.9	7.8	7.7	7.5	7.3	7.1	7.1	36.0
38.0									7.1/37.3m	7.3	7.2	7.0	6.9	6.7	6.5	6.3	6.3	38.0
40.0										6.0/39.9m	6.4	6.4	6.3	6.0	5.9	5.6	5.6	40.0
42.0											5.4	5.7	5.7	5.4	5.2	5.0	5.0	42.0
44.0											5.1/42.6m	4.7	5.0	4.9	4.7	4.5	4.5	44.0
46.0												4.1/45.2m	4.2	4.3	4.2	3.9	3.9	46.0
48.0													3.4/47.9m	3.6	3.6	3.4	3.4	48.0
50.0														2.7	3.0	2.9	2.9	50.0
52.0														2.5/50.5m	2.3	2.4	2.4	52.0

※表中の太線で囲まれた部分は、ブーム等の強度によって定められた値です。

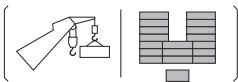

### ▶ 補助シーブ定格総荷重表

(59.1tカウンタウエイト / 35tフック装着 / 1枚または2枚補助シーブ付き)

(単位：t)

作業半径 (m)	ブーム長さ (m)																作業半径 (m)
	15.2	18.3	21.3	24.4	27.4	30.5	33.5	36.6	39.6	42.7	45.7	48.8	51.8	54.9	57.9	61.0	
5.0	15.5/5.3m	15.5/5.8m															5.0
6.0	15.5	15.5	15.5/6.3m	15.5/6.9m													6.0
7.0	15.5	15.5	15.5	15.5	15.5/7.4m	15.5/7.9m											7.0
8.0	15.5	15.5	15.5	15.5	15.5	15.5	15.5/8.4m										8.0
9.0	15.5	15.5	15.5	15.5	15.5	15.5	15.5	15.5	15.5/9.5m								9.0
10.0	15.5	15.5	15.5	15.5	15.5	15.5	15.5	15.5	15.5	15.5	15.5/10.6m	15.5/11.1m	15.5/11.6m				10.0
12.0	15.5	15.5	15.5	15.5	15.5	15.5	15.5	15.5	15.5	15.5	15.5	15.5	15.5	15.5/12.2m	15.5/12.7m	15.5/13.2m	12.0
14.0	15.5	15.5	15.5	15.5	15.5	15.5	15.5	15.5	15.5	15.5	15.5	15.5	15.5	15.5	15.5	15.5	14.0
16.0	15.5	15.5	15.5	15.5	15.5	15.5	15.5	15.5	15.5	15.5	15.5	15.5	15.5	15.5	15.5	15.5	16.0
18.0	15.5/16.2m	15.5	15.5	15.5	15.5	15.5	15.5	15.5	15.5	15.5	15.5	15.5	15.5	15.5	15.5	15.5	18.0
20.0		15.5/18.8m	15.5	15.5	15.5	15.5	15.5	15.5	15.5	15.5	15.5	15.5	15.5	15.5	15.5	15.5	20.0
22.0			15.5/21.5m	15.5	15.5	15.5	15.5	15.5	15.5	15.5	15.5	15.5	15.5	15.5	15.5	15.5	22.0
24.0				14.6	15.5	15.5	15.5	15.5	15.5	15.5	15.5	15.5	15.5	15.3	15.2	15.0	24.0
26.0				14.4/24.1m	13.7	14.8	14.6	14.4	14.3	14.1	13.9	13.8	13.7	13.5	13.3	13.1	26.0
28.0					12.6/26.7m	12.7	13.1	12.9	12.8	12.6	12.4	12.3	12.2	12.0	11.8	11.6	28.0
30.0						11.2/29.4m	11.7	11.6	11.5	11.3	11.1	11.0	10.9	10.7	10.5	10.3	30.0
32.0							9.6	10.5	10.4	10.2	10.0	9.8	9.7	9.5	9.4	9.1	32.0
34.0								8.9	9.4	9.2	9.0	8.9	8.8	8.5	8.4	8.1	34.0
36.0								8.4/34.7m	8.2	8.4	8.1	8.0	7.9	7.7	7.5	7.3	36.0
38.0									7.3/37.3m	7.5	7.4	7.2	7.1	6.9	6.7	6.5	38.0
40.0										6.2/39.9m	6.6	6.6	6.5	6.2	6.1	5.8	40.0
42.0											5.6	5.9	5.9	5.6	5.4	5.2	42.0
44.0											5.3/42.6m	4.9	5.2	5.1	4.9	4.7	44.0
46.0												4.3/45.2m	4.4	4.5	4.4	4.1	46.0
48.0													3.6/47.9m	3.8	3.8	3.6	48.0
50.0														2.9	3.2	3.1	50.0
52.0														2.7/50.5m	2.5	2.6	52.0
54.0															2.1/53.1m	2.0	54.0

※表中の太線で囲まれた部分は、ブーム等の強度によって定められた値です。

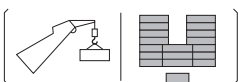

### ▶ 補助シーブ定格総荷重表

(59.1tカウンタウエイト / 主ブームにフックなし / 1枚または2枚補助シーブ付き)

(単位：t)

作業半径 (m)	ブーム長さ (m)																作業半径 (m)
	15.2	18.3	21.3	24.4	27.4	30.5	33.5	36.6	39.6	42.7	45.7	48.8	51.8	54.9	57.9	61.0	
5.0	15.5/5.3m	15.5/5.8m															5.0
6.0	15.5	15.5	15.5/6.3m	15.5/6.9m													6.0
7.0	15.5	15.5	15.5	15.5	15.5/7.4m	15.5/7.9m											7.0
8.0	15.5	15.5	15.5	15.5	15.5	15.5	15.5/8.4m										8.0
9.0	15.5	15.5	15.5	15.5	15.5	15.5	15.5	15.5	15.5/9.5m								9.0
10.0	15.5	15.5	15.5	15.5	15.5	15.5	15.5	15.5	15.5	15.5	15.5/10.6m	15.5/11.1m	15.5/11.6m				10.0
12.0	15.5	15.5	15.5	15.5	15.5	15.5	15.5	15.5	15.5	15.5	15.5	15.5	15.5	15.5/12.2m	15.5/12.7m	15.5/13.2m	12.0
14.0	15.5	15.5	15.5	15.5	15.5	15.5	15.5	15.5	15.5	15.5	15.5	15.5	15.5	15.5	15.5	15.5	14.0
16.0	15.5	15.5	15.5	15.5	15.5	15.5	15.5	15.5	15.5	15.5	15.5	15.5	15.5	15.5	15.5	15.5	16.0
18.0	15.5/16.2m	15.5	15.5	15.5	15.5	15.5	15.5	15.5	15.5	15.5	15.5	15.5	15.5	15.5	15.5	15.5	18.0
20.0		15.5/18.8m	15.5	15.5	15.5	15.5	15.5	15.5	15.5	15.5	15.5	15.5	15.5	15.5	15.5	15.5	20.0
22.0			15.5/21.5m	15.5	15.5	15.5	15.5	15.5	15.5	15.5	15.5	15.5	15.5	15.5	15.5	15.5	22.0
24.0				15.3	15.5	15.5	15.5	15.5	15.5	15.5	15.5	15.5	15.5	15.5	15.5	15.5	24.0
26.0				15.1/24.1m	14.4	15.5	15.3	15.1	15.0	14.8	14.6	14.5	14.4	14.2	14.0	13.8	26.0
28.0					13.3/26.7m	13.4	13.8	13.6	13.5	13.3	13.1	13.0	12.9	12.7	12.5	12.3	28.0
30.0						11.9/29.4m	12.4	12.3	12.2	12.0	11.8	11.7	11.6	11.4	11.2	11.0	30.0
32.0							10.3	11.2	11.1	10.9	10.7	10.5	10.4	10.2	10.1	9.8	32.0
34.0								9.6	10.1	9.9	9.7	9.6	9.5	9.2	9.1	8.8	34.0
36.0								9.1/34.7m	8.9	9.1	8.8	8.7	8.6	8.4	8.2	8.0	36.0
38.0									8.0/37.3m	8.2	8.1	7.9	7.8	7.6	7.4	7.2	38.0
40.0										6.9/39.9m	7.3	7.3	7.2	6.9	6.8	6.5	40.0
42.0											6.3	6.6	6.6	6.3	6.1	5.9	42.0
44.0											6.0/42.6m	5.6	5.9	5.8	5.6	5.4	44.0
46.0												5.0/45.2m	5.1	5.2	5.1	4.8	46.0
48.0													4.3/47.9m	4.5	4.5	4.3	48.0
50.0														3.6	3.9	3.8	50.0
52.0														3.4/50.5m	3.2	3.3	52.0
54.0															2.8/53.1m	2.7	54.0
56.0																2.1/55.8m	56.0

※表中の太線で囲まれた部分は、ブーム等の強度によって定められた値です。

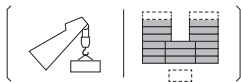

### 主ブーム定格総荷重表

(53.1tカウンタウエイト[オプション]/補助シーブなし)

(単位: t)

作業半径 (m)	ブーム長さ (m)															作業半径 (m)	
	15.2	18.3	21.3	24.4	27.4	30.5	33.5	36.6	39.6	42.7	45.7	48.8	51.8	54.9	57.9		61.0
4.5	120.0																4.5
5.0	120.0	112.0/5.1m	98.0/5.6m														5.0
6.0	110.4	110.1	98.0	84.0/6.1m	70.0/6.7m												6.0
7.0	90.2	90.1	90.0	84.0	70.0	70.0/7.2m	56.0/7.7m										7.0
8.0	72.7	72.6	72.5	72.4	70.0	70.0	56.0	56.0/8.2m	42.0/8.8m								8.0
9.0	60.7	60.6	60.5	60.4	60.3	60.2	56.0	56.0	42.0	42.0/9.3m	42.0/9.8m						9.0
10.0	52.1	51.9	51.8	51.7	51.6	51.5	51.4	51.2	42.0	42.0	42.0	28.0/10.4m	28.0/10.9m	28.0/11.4m			10.0
12.0	40.3	40.1	40.0	39.9	39.8	39.6	39.6	39.4	39.4	39.2	39.0	28.0	28.0	28.0	28.0	28.0/12.5m	12.0
14.0	32.8	32.6	32.4	32.3	32.1	32.0	31.9	31.7	31.7	31.5	31.3	28.0	28.0	28.0	28.0	27.2	14.0
16.0	29.1/14.9m	27.3	27.1	27.0	26.8	26.7	26.6	26.4	26.3	26.2	26.0	26.0	25.8	25.6	25.5	25.3	16.0
18.0		24.3/17.5m	23.2	23.1	22.9	22.7	22.6	22.4	22.4	22.2	22.0	22.0	21.8	21.6	21.5	21.3	18.0
20.0			20.2	20.1	19.9	19.7	19.6	19.4	19.3	19.2	19.0	18.9	18.8	18.6	18.4	18.2	20.0
22.0			20.1/20.1m	17.7	17.5	17.3	17.2	17.0	16.9	16.8	16.5	16.5	16.4	16.2	16.0	15.8	22.0
24.0				16.9/22.8m	15.6	15.4	15.3	15.0	15.0	14.8	14.6	14.6	14.4	14.2	14.0	13.8	24.0
26.0					14.4/25.4m	13.8	13.7	13.4	13.4	13.2	13.0	12.9	12.8	12.6	12.4	12.2	26.0
28.0						12.5	12.4	12.1	12.0	11.8	11.6	11.6	11.4	11.2	11.0	10.8	28.0
30.0							11.2	11.0	10.9	10.7	10.5	10.4	10.2	10.0	9.9	9.6	30.0
32.0							10.9/30.7m	10.0	9.9	9.7	9.5	9.4	9.2	9.0	8.9	8.6	32.0
34.0								9.4/33.3m	9.0	8.8	8.6	8.5	8.4	8.1	8.0	7.8	34.0
36.0									8.3	8.1	7.8	7.8	7.6	7.4	7.2	7.0	36.0
38.0										7.4	7.2	7.1	6.9	6.7	6.5	6.3	38.0
40.0										7.3/38.6m	6.6	6.5	6.3	6.1	5.9	5.7	40.0
42.0											6.3/41.2m	6.0	5.8	5.6	5.4	5.1	42.0
44.0												5.5/43.9m	5.3	5.1	4.8	4.5	44.0
46.0													4.9	4.6	4.3	4.0	46.0
48.0													4.8/46.5m	4.1	3.9	3.5	48.0
50.0														3.9/49.2m	3.4	3.1	50.0
52.0															3.1/51.8m	2.7	52.0
54.0																2.4	54.0
56.0																2.3/54.4m	56.0

※表中の太線で囲まれた部分は、ブーム等の強度によって定められた値です。

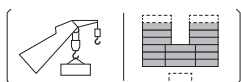

### 主ブーム定格総荷重表

(53.1tカウンタウエイト[オプション]/1枚または2枚補助シーブ付き / 軽量フック付き)

(単位: t)

作業半径 (m)	ブーム長さ (m)															作業半径 (m)	
	15.2	18.3	21.3	24.4	27.4	30.5	33.5	36.6	39.6	42.7	45.7	48.8	51.8	54.9	57.9		61.0
4.5	118.8																4.5
5.0	118.8	110.8/5.1m	96.8/5.6m														5.0
6.0	109.2	108.9	96.8	82.8/6.1m	68.8/6.7m												6.0
7.0	89.0	88.9	88.8	82.8	68.8	68.8/7.2m	54.8/7.7m										7.0
8.0	71.5	71.4	71.3	71.2	68.8	68.8	54.8	54.8/8.2m	40.8/8.8m								8.0
9.0	59.5	59.4	59.3	59.2	59.1	59.0	54.8	54.8	40.8	40.8/9.3m	40.8/9.8m						9.0
10.0	50.9	50.7	50.6	50.5	50.4	50.3	50.2	50.0	40.8	40.8	40.8	26.8/10.4m	26.8/10.9m	26.8/11.4m			10.0
12.0	39.1	38.9	38.8	38.7	38.6	38.4	38.4	38.2	38.2	38.0	37.8	26.8	26.8	26.8	26.8	26.8/12.5m	12.0
14.0	31.6	31.4	31.2	31.1	30.9	30.8	30.7	30.5	30.5	30.3	30.1	26.8	26.8	26.8	26.8	26.0	14.0
16.0	27.9/14.9m	26.1	25.9	25.8	25.6	25.5	25.4	25.2	25.1	25.0	24.8	24.8	24.6	24.4	24.3	24.1	16.0
18.0		23.1/17.5m	22.0	21.9	21.7	21.5	21.4	21.2	21.2	21.0	20.8	20.8	20.6	20.4	20.3	20.1	18.0
20.0			19.0	18.9	18.7	18.5	18.4	18.2	18.1	18.0	17.8	17.7	17.6	17.4	17.2	17.0	20.0
22.0			18.9/20.1m	16.5	16.3	16.1	16.0	15.8	15.7	15.6	15.3	15.3	15.2	15.0	14.8	14.6	22.0
24.0				15.7/22.8m	14.4	14.2	14.1	13.8	13.8	13.6	13.4	13.4	13.2	13.0	12.8	12.6	24.0
26.0					13.2/25.4m	12.6	12.5	12.2	12.2	12.0	11.8	11.7	11.6	11.4	11.2	11.0	26.0
28.0						11.3	11.2	10.9	10.8	10.6	10.4	10.4	10.2	10.0	9.8	9.6	28.0
30.0							10.0	9.8	9.7	9.5	9.3	9.2	9.0	8.8	8.7	8.4	30.0
32.0							9.7/30.7m	8.8	8.7	8.5	8.3	8.2	8.0	7.8	7.7	7.4	32.0
34.0								8.2/33.3m	7.8	7.6	7.4	7.3	7.2	6.9	6.8	6.6	34.0
36.0									7.1	6.9	6.6	6.6	6.4	6.2	6.0	5.8	36.0
38.0										6.2	6.0	5.9	5.7	5.5	5.3	5.1	38.0
40.0										6.1/38.6m	5.4	5.3	5.1	4.9	4.7	4.5	40.0
42.0											5.1/41.2m	4.8	4.6	4.4	4.2	3.9	42.0
44.0												4.3/43.9m	4.1	3.9	3.6	3.3	44.0
46.0													3.7	3.4	3.1	2.8	46.0
48.0													3.6/46.5m	2.9	2.7	2.3	48.0
50.0														2.7/49.2m	2.2		50.0

※表中の太線で囲まれた部分は、ブーム等の強度によって定められた値です。

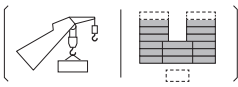

### 主ブーム定格総荷重表

(53.1tカウンタウエイト[オプション] / 1枚または2枚補助シーブ付き / ボールフック付き)

(単位：t)

作業半径 (m)	ブーム長さ (m)															作業半径 (m)	
	15.2	18.3	21.3	24.4	27.4	30.5	33.5	36.6	39.6	42.7	45.7	48.8	51.8	54.9	57.9		61.0
4.5	118.5																4.5
5.0	118.5	110.5/5.1m	96.5/5.6m														5.0
6.0	108.9	108.6	96.5	82.5/6.1m	68.5/6.7m												6.0
7.0	88.7	88.6	88.5	82.5	68.5	68.5/7.2m	54.5/7.7m										7.0
8.0	71.2	71.1	71.0	70.9	68.5	68.5	54.5	54.5/8.2m	40.5/8.8m								8.0
9.0	59.2	59.1	59.0	58.9	58.8	58.7	54.5	54.5	40.5	40.5/9.3m	40.5/9.8m						9.0
10.0	50.6	50.4	50.3	50.2	50.1	50.0	49.9	49.7	40.5	40.5	40.5	26.5/10.4m	26.5/10.9m	26.5/11.4m			10.0
12.0	38.8	38.6	38.5	38.4	38.3	38.1	38.1	37.9	37.9	37.7	37.5	26.5	26.5	26.5	26.5	26.5/12.5m	12.0
14.0	31.3	31.1	30.9	30.8	30.6	30.5	30.4	30.2	30.2	30.0	29.8	26.5	26.5	26.5	26.5	25.7	14.0
16.0	27.6/14.9m	25.8	25.6	25.5	25.3	25.2	25.1	24.9	24.8	24.7	24.5	24.5	24.3	24.1	24.0	23.8	16.0
18.0		22.8/17.5m	21.7	21.6	21.4	21.2	21.1	20.9	20.9	20.7	20.5	20.5	20.3	20.1	20.0	19.8	18.0
20.0			18.7	18.6	18.4	18.2	18.1	17.9	17.8	17.7	17.5	17.4	17.3	17.1	16.9	16.7	20.0
22.0			18.6/20.1m	16.2	16.0	15.8	15.7	15.5	15.4	15.3	15.0	15.0	14.9	14.7	14.5	14.3	22.0
24.0				15.4/22.8m	14.1	13.9	13.8	13.5	13.5	13.3	13.1	13.1	12.9	12.7	12.5	12.3	24.0
26.0					12.9/25.4m	12.3	12.2	11.9	11.9	11.7	11.5	11.4	11.3	11.1	10.9	10.7	26.0
28.0						11.0	10.9	10.6	10.5	10.3	10.1	10.1	9.9	9.7	9.5	9.3	28.0
30.0							9.7	9.5	9.4	9.2	9.0	8.9	8.7	8.5	8.4	8.1	30.0
32.0							9.4/30.7m	8.5	8.4	8.2	8.0	7.9	7.7	7.5	7.4	7.1	32.0
34.0								7.9/33.3m	7.5	7.3	7.1	7.0	6.9	6.6	6.5	6.3	34.0
36.0									6.8	6.6	6.3	6.3	6.1	5.9	5.7	5.5	36.0
38.0										5.9	5.7	5.6	5.4	5.2	5.0	4.8	38.0
40.0										5.8/38.6m	5.1	5.0	4.8	4.6	4.4	4.2	40.0
42.0											4.8/41.2m	4.5	4.3	4.1	3.9	3.6	42.0
44.0												4.0/43.9m	3.8	3.6	3.3	3.0	44.0
46.0													3.4	3.1	2.8	2.5	46.0
48.0													3.3/46.5m	2.6	2.4	2.0	48.0
50.0														2.4/49.2m			50.0

※表中の太線で囲まれた部分は、ブーム等の強度によって定められた値です。

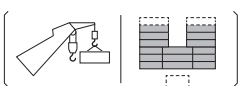

### 補助シーブ定格総荷重表

(53.1tカウンタウエイト[オプション] / 120tフック装着 / 1枚または2枚補助シーブ付き)

(単位：t)

作業半径 (m)	ブーム長さ (m)															作業半径 (m)	
	15.2	18.3	21.3	24.4	27.4	30.5	33.5	36.6	39.6	42.7	45.7	48.8	51.8	54.9	57.9		61.0
5.0	15.5/5.3m	15.5/5.8m															5.0
6.0	15.5	15.5	15.5/6.3m	15.5/6.9m													6.0
7.0	15.5	15.5	15.5	15.5	15.5/7.4m	15.5/7.9m											7.0
8.0	15.5	15.5	15.5	15.5	15.5	15.5	15.5/8.4m										8.0
9.0	15.5	15.5	15.5	15.5	15.5	15.5	15.5	15.5	15.5/9.5m								9.0
10.0	15.5	15.5	15.5	15.5	15.5	15.5	15.5	15.5	15.5	15.5	15.5/10.6m	15.5/11.1m	15.5/11.6m				10.0
12.0	15.5	15.5	15.5	15.5	15.5	15.5	15.5	15.5	15.5	15.5	15.5	15.5	15.5	15.5/12.2m	15.5/12.7m	15.5/13.2m	12.0
14.0	15.5	15.5	15.5	15.5	15.5	15.5	15.5	15.5	15.5	15.5	15.5	15.5	15.5	15.5	15.5	15.5	14.0
16.0	15.5	15.5	15.5	15.5	15.5	15.5	15.5	15.5	15.5	15.5	15.5	15.5	15.5	15.5	15.5	15.5	16.0
18.0	15.5/16.2m	15.5	15.5	15.5	15.5	15.5	15.5	15.5	15.5	15.5	15.5	15.5	15.5	15.5	15.5	15.5	18.0
20.0		15.5/18.8m	15.5	15.5	15.5	15.5	15.5	15.5	15.5	15.5	15.5	15.5	15.5	15.5	15.5	15.5	20.0
22.0			15.5/21.5m	15.4	15.2	15.0	14.9	14.7	14.6	14.5	14.2	14.2	14.1	13.9	13.7	13.5	22.0
24.0				13.4	13.3	13.1	13.0	12.7	12.7	12.5	12.3	12.3	12.1	11.9	11.7	11.5	24.0
26.0				13.3/24.1m	11.5	11.5	11.4	11.1	11.1	10.9	10.7	10.6	10.5	10.3	10.1	9.9	26.0
28.0					10.9/26.7m	10.2	10.1	9.8	9.7	9.5	9.3	9.3	9.1	8.9	8.7	8.5	28.0
30.0						9.3/29.4m	8.9	8.7	8.6	8.4	8.2	8.1	7.9	7.7	7.6	7.3	30.0
32.0							7.7	7.7	7.6	7.4	7.2	7.1	6.9	6.7	6.6	6.3	32.0
34.0								7.1	6.7	6.5	6.3	6.2	6.1	5.8	5.7	5.5	34.0
36.0								6.9/34.7m	6.0	5.8	5.5	5.5	5.3	5.1	4.9	4.7	36.0
38.0									5.5/37.3m	5.1	4.9	4.8	4.6	4.4	4.2	4.0	38.0
40.0										4.4/39.9m	4.3	4.2	4.0	3.8	3.6	3.4	40.0
42.0											4.0	3.7	3.5	3.3	3.1	2.8	42.0
44.0											3.9/42.6m	3.2	3.0	2.8	2.5	2.2	44.0
46.0												2.9/45.2m	2.6	2.3	2.0		46.0
48.0													2.2/47.9m				48.0

※表中の太線で囲まれた部分は、ブーム等の強度によって定められた値です。

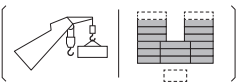

### ▶ 補助シーブ定格総荷重表

(53.1tカウンタウエイト[オプション]/70tフック装着 / 1枚または2枚補助シーブ付き)

(単位：t)

作業半径 (m)	ブーム長さ (m)															作業半径 (m)	
	15.2	18.3	21.3	24.4	27.4	30.5	33.5	36.6	39.6	42.7	45.7	48.8	51.8	54.9	57.9		61.0
5.0	15.5/5.3m	15.5/5.8m															5.0
6.0	15.5	15.5	15.5/6.3m	15.5/6.9m													6.0
7.0	15.5	15.5	15.5	15.5	15.5/7.4m	15.5/7.9m											7.0
8.0	15.5	15.5	15.5	15.5	15.5	15.5	15.5/8.4m										8.0
9.0	15.5	15.5	15.5	15.5	15.5	15.5	15.5	15.5/9.5m									9.0
10.0	15.5	15.5	15.5	15.5	15.5	15.5	15.5	15.5	15.5	15.5	15.5/10.6m	15.5/11.1m	15.5/11.6m				10.0
12.0	15.5	15.5	15.5	15.5	15.5	15.5	15.5	15.5	15.5	15.5	15.5	15.5	15.5	15.5/12.2m	15.5/12.7m	15.5/13.2m	12.0
14.0	15.5	15.5	15.5	15.5	15.5	15.5	15.5	15.5	15.5	15.5	15.5	15.5	15.5	15.5	15.5	15.5	14.0
16.0	15.5	15.5	15.5	15.5	15.5	15.5	15.5	15.5	15.5	15.5	15.5	15.5	15.5	15.5	15.5	15.5	16.0
18.0	15.5/16.2m	15.5	15.5	15.5	15.5	15.5	15.5	15.5	15.5	15.5	15.5	15.5	15.5	15.5	15.5	15.5	18.0
20.0		15.5/18.8m	15.5	15.5	15.5	15.5	15.5	15.5	15.5	15.5	15.5	15.5	15.5	15.5	15.5	15.5	20.0
22.0			15.5/21.5m	15.5	15.5	15.5	15.5	15.3	15.2	15.1	14.8	14.8	14.7	14.5	14.3	14.1	22.0
24.0				14.0	13.9	13.7	13.6	13.3	13.3	13.1	12.9	12.9	12.7	12.5	12.3	12.1	24.0
26.0				13.9/24.1m	12.1	12.1	12.0	11.7	11.7	11.5	11.3	11.2	11.1	10.9	10.7	10.5	26.0
28.0					11.5/26.7m	10.8	10.7	10.4	10.3	10.1	9.9	9.9	9.7	9.5	9.3	9.1	28.0
30.0						9.9/29.4m	9.5	9.3	9.2	9.0	8.8	8.7	8.5	8.3	8.2	7.9	30.0
32.0							8.3	8.3	8.2	8.0	7.8	7.7	7.5	7.3	7.2	6.9	32.0
34.0								7.7	7.3	7.1	6.9	6.8	6.7	6.4	6.3	6.1	34.0
36.0								7.5/34.7m	6.6	6.4	6.1	6.1	5.9	5.7	5.5	5.3	36.0
38.0									6.1/37.3m	5.7	5.5	5.4	5.2	5.0	4.8	4.6	38.0
40.0										5.0/39.9m	4.9	4.8	4.6	4.4	4.2	4.0	40.0
42.0											4.6	4.3	4.1	3.9	3.7	3.4	42.0
44.0											4.5/42.6m	3.8	3.6	3.4	3.1	2.8	44.0
46.0												3.5/45.2m	3.2	2.9	2.6	2.3	46.0
48.0													2.8/47.9m	2.4	2.2		48.0
50.0														2.2			50.0
52.0														2.2/50.5m			52.0

※表中の太線で囲まれた部分は、ブーム等の強度によって定められた値です。

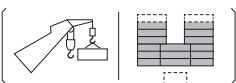

### ▶ 補助シーブ定格総荷重表

(53.1tカウンタウエイト[オプション]/50tフック装着 / 1枚または2枚補助シーブ付き)

(単位：t)

作業半径 (m)	ブーム長さ (m)															作業半径 (m)	
	15.2	18.3	21.3	24.4	27.4	30.5	33.5	36.6	39.6	42.7	45.7	48.8	51.8	54.9	57.9		61.0
5.0	15.5/5.3m	15.5/5.8m															5.0
6.0	15.5	15.5	15.5/6.3m	15.5/6.9m													6.0
7.0	15.5	15.5	15.5	15.5	15.5/7.4m	15.5/7.9m											7.0
8.0	15.5	15.5	15.5	15.5	15.5	15.5	15.5/8.4m										8.0
9.0	15.5	15.5	15.5	15.5	15.5	15.5	15.5	15.5	15.5/9.5m								9.0
10.0	15.5	15.5	15.5	15.5	15.5	15.5	15.5	15.5	15.5	15.5	15.5/10.6m	15.5/11.1m	15.5/11.6m				10.0
12.0	15.5	15.5	15.5	15.5	15.5	15.5	15.5	15.5	15.5	15.5	15.5	15.5	15.5	15.5/12.2m	15.5/12.7m	15.5/13.2m	12.0
14.0	15.5	15.5	15.5	15.5	15.5	15.5	15.5	15.5	15.5	15.5	15.5	15.5	15.5	15.5	15.5	15.5	14.0
16.0	15.5	15.5	15.5	15.5	15.5	15.5	15.5	15.5	15.5	15.5	15.5	15.5	15.5	15.5	15.5	15.5	16.0
18.0	15.5/16.2m	15.5	15.5	15.5	15.5	15.5	15.5	15.5	15.5	15.5	15.5	15.5	15.5	15.5	15.5	15.5	18.0
20.0		15.5/18.8m	15.5	15.5	15.5	15.5	15.5	15.5	15.5	15.5	15.5	15.5	15.5	15.5	15.5	15.5	20.0
22.0			15.5/21.5m	15.5	15.5	15.5	15.5	15.5	15.5	15.4	15.1	15.1	15.0	14.8	14.6	14.4	22.0
24.0				14.3	14.2	14.0	13.9	13.6	13.6	13.4	13.2	13.2	13.0	12.8	12.6	12.4	24.0
26.0				14.2/24.1m	12.4	12.4	12.3	12.0	12.0	11.8	11.6	11.5	11.4	11.2	11.0	10.8	26.0
28.0					11.8/26.7m	11.1	11.0	10.7	10.6	10.4	10.2	10.2	10.0	9.8	9.6	9.4	28.0
30.0						10.2/29.4m	9.8	9.6	9.5	9.3	9.1	9.0	8.8	8.6	8.5	8.2	30.0
32.0							8.6	8.6	8.5	8.3	8.1	8.0	7.8	7.6	7.5	7.2	32.0
34.0								8.0	7.6	7.4	7.2	7.1	7.0	6.7	6.6	6.4	34.0
36.0								7.8/34.7m	6.9	6.7	6.4	6.4	6.2	6.0	5.8	5.6	36.0
38.0									6.4/37.3m	6.0	5.8	5.7	5.5	5.3	5.1	4.9	38.0
40.0										5.3/39.9m	5.2	5.1	4.9	4.7	4.5	4.3	40.0
42.0											4.9	4.6	4.4	4.2	4.0	3.7	42.0
44.0											4.8/42.6m	4.1	3.9	3.7	3.4	3.1	44.0
46.0												3.8/45.2m	3.5	3.2	2.9	2.6	46.0
48.0													3.1/47.9m	2.7	2.5	2.1	48.0
50.0														2.5	2.0		50.0
52.0														2.5/50.5m			52.0

※表中の太線で囲まれた部分は、ブーム等の強度によって定められた値です。



### ▶ 補助シーブ定格総荷重表

(53.1tカウンタウエイト[オプション]/35tフック装着/1枚または2枚補助シーブ付き)

(単位：t)

作業半径 (m)	ブーム長さ (m)																作業半径 (m)	
	15.2	18.3	21.3	24.4	27.4	30.5	33.5	36.6	39.6	42.7	45.7	48.8	51.8	54.9	57.9	61.0		
5.0	15.5/5.3m	15.5/5.8m															5.0	
6.0	15.5	15.5	15.5/6.3m	15.5/6.9m													6.0	
7.0	15.5	15.5	15.5	15.5	15.5/7.4m	15.5/7.9m											7.0	
8.0	15.5	15.5	15.5	15.5	15.5	15.5	15.5/8.4m										8.0	
9.0	15.5	15.5	15.5	15.5	15.5	15.5	15.5	15.5/9.5m									9.0	
10.0	15.5	15.5	15.5	15.5	15.5	15.5	15.5	15.5	15.5	15.5	15.5/10.6m	15.5/11.1m	15.5/11.6m				10.0	
12.0	15.5	15.5	15.5	15.5	15.5	15.5	15.5	15.5	15.5	15.5	15.5	15.5	15.5	15.5/12.2m	15.5/12.7m	15.5/13.2m	12.0	
14.0	15.5	15.5	15.5	15.5	15.5	15.5	15.5	15.5	15.5	15.5	15.5	15.5	15.5	15.5	15.5	15.5	14.0	
16.0	15.5	15.5	15.5	15.5	15.5	15.5	15.5	15.5	15.5	15.5	15.5	15.5	15.5	15.5	15.5	15.5	16.0	
18.0	15.5/16.2m	15.5	15.5	15.5	15.5	15.5	15.5	15.5	15.5	15.5	15.5	15.5	15.5	15.5	15.5	15.5	18.0	
20.0		15.5/18.8m	15.5	15.5	15.5	15.5	15.5	15.5	15.5	15.5	15.5	15.5	15.5	15.5	15.5	15.5	20.0	
22.0			15.5/21.5m	15.5	15.5	15.5	15.5	15.5	15.5	15.5	15.5	15.3	15.3	15.2	15.0	14.8	14.6	22.0
24.0				14.5	14.4	14.2	14.1	13.8	13.8	13.6	13.4	13.4	13.2	13.0	12.8	12.6	24.0	
26.0				14.4/24.1m	12.6	12.6	12.5	12.2	12.2	12.0	11.8	11.7	11.6	11.4	11.2	11.0	26.0	
28.0					12.0/26.7m	11.3	11.2	10.9	10.8	10.6	10.4	10.4	10.2	10.0	9.8	9.6	28.0	
30.0						10.4/29.4m	10.0	9.8	9.7	9.5	9.3	9.2	9.0	8.8	8.7	8.4	30.0	
32.0							8.8	8.8	8.7	8.5	8.3	8.2	8.0	7.8	7.7	7.4	32.0	
34.0								8.2	7.8	7.6	7.4	7.3	7.2	6.9	6.8	6.6	34.0	
36.0								8.0/34.7m	7.1	6.9	6.6	6.6	6.4	6.2	6.0	5.8	36.0	
38.0									6.6/37.3m	6.2	6.0	5.9	5.7	5.5	5.3	5.1	38.0	
40.0										5.5/39.9m	5.4	5.3	5.1	4.9	4.7	4.5	40.0	
42.0											5.1	4.8	4.6	4.4	4.2	3.9	42.0	
44.0											5.0/42.6m	4.3	4.1	3.9	3.6	3.3	44.0	
46.0												4.0/45.2m	3.7	3.4	3.1	2.8	46.0	
48.0													3.3/47.9m	2.9	2.7	2.3	48.0	
50.0														2.7	2.2		50.0	
52.0															2.7/50.5m		52.0	

※表中の太線で囲まれた部分は、ブーム等の強度によって定められた値です。

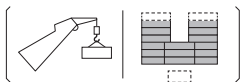

### ▶ 補助シーブ定格総荷重表

(53.1tカウンタウエイト[オプション]/主ブームにフックなし/1枚または2枚補助シーブ付き)

(単位：t)

作業半径 (m)	ブーム長さ (m)																作業半径 (m)	
	15.2	18.3	21.3	24.4	27.4	30.5	33.5	36.6	39.6	42.7	45.7	48.8	51.8	54.9	57.9	61.0		
5.0	15.5/5.3m	15.5/5.8m															5.0	
6.0	15.5	15.5	15.5/6.3m	15.5/6.9m													6.0	
7.0	15.5	15.5	15.5	15.5	15.5/7.4m	15.5/7.9m											7.0	
8.0	15.5	15.5	15.5	15.5	15.5	15.5	15.5/8.4m										8.0	
9.0	15.5	15.5	15.5	15.5	15.5	15.5	15.5	15.5/9.5m									9.0	
10.0	15.5	15.5	15.5	15.5	15.5	15.5	15.5	15.5	15.5	15.5	15.5/10.6m	15.5/11.1m	15.5/11.6m				10.0	
12.0	15.5	15.5	15.5	15.5	15.5	15.5	15.5	15.5	15.5	15.5	15.5	15.5	15.5	15.5/12.2m	15.5/12.7m	15.5/13.2m	12.0	
14.0	15.5	15.5	15.5	15.5	15.5	15.5	15.5	15.5	15.5	15.5	15.5	15.5	15.5	15.5	15.5	15.5	14.0	
16.0	15.5	15.5	15.5	15.5	15.5	15.5	15.5	15.5	15.5	15.5	15.5	15.5	15.5	15.5	15.5	15.5	16.0	
18.0	15.5/16.2m	15.5	15.5	15.5	15.5	15.5	15.5	15.5	15.5	15.5	15.5	15.5	15.5	15.5	15.5	15.5	18.0	
20.0		15.5/18.8m	15.5	15.5	15.5	15.5	15.5	15.5	15.5	15.5	15.5	15.5	15.5	15.5	15.5	15.5	20.0	
22.0			15.5/21.5m	15.5	15.5	15.5	15.5	15.5	15.5	15.5	15.5	15.5	15.5	15.5	15.5	15.3	22.0	
24.0				15.2	15.1	14.9	14.8	14.5	14.5	14.3	14.1	14.1	13.9	13.7	13.5	13.3	24.0	
26.0				15.1/24.1m	13.3	13.3	13.2	12.9	12.9	12.7	12.5	12.4	12.3	12.1	11.9	11.7	26.0	
28.0					12.7/26.7m	12.0	11.9	11.6	11.5	11.3	11.1	11.1	10.9	10.7	10.5	10.3	28.0	
30.0						11.1/29.4m	10.7	10.5	10.4	10.2	10.0	9.9	9.7	9.5	9.4	9.1	30.0	
32.0							9.5	9.5	9.4	9.2	9.0	8.9	8.7	8.5	8.4	8.1	32.0	
34.0								8.9	8.5	8.3	8.1	8.0	7.9	7.6	7.5	7.3	34.0	
36.0								8.7/34.7m	7.8	7.6	7.3	7.3	7.1	6.9	6.7	6.5	36.0	
38.0									7.3/37.3m	6.9	6.7	6.6	6.4	6.2	6.0	5.8	38.0	
40.0										6.2/39.9m	6.1	6.0	5.8	5.6	5.4	5.2	40.0	
42.0											5.8	5.5	5.3	5.1	4.9	4.6	42.0	
44.0											5.7/42.6m	5.0	4.8	4.6	4.3	4.0	44.0	
46.0												4.7/45.2m	4.4	4.1	3.8	3.5	46.0	
48.0													4.0/47.9m	3.6	3.4	3.0	48.0	
50.0														3.4	2.9	2.6	50.0	
52.0															3.4/50.5m	2.6	2.2	52.0
54.0																2.4/53.1m		54.0

※表中の太線で囲まれた部分は、ブーム等の強度によって定められた値です。

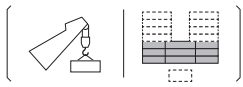

### 主ブーム定格総荷重表

(29.1tカウンタウイト[オプション] / 補助シーブなし)

(単位：t)

作業半径 (m)	ブーム長さ (m)															作業半径 (m)
	15.2	18.3	21.3	24.4	27.4	30.5	33.5	36.6	39.6	42.7	45.7	48.8	51.8	54.9	57.9	
4.5	120.0															4.5
5.0	117.5	112.0/5.1m	95.0/5.6m													5.0
6.0	83.5	83.4	83.4	78.2/6.1m	67.5/6.7m											6.0
7.0	62.9	62.9	62.8	62.8	62.7	59.5/7.2m	52.5/7.7m									7.0
8.0	50.5	50.4	50.3	50.2	50.1	50.0	50.0	47.3/8.2m	42.0/8.8m							8.0
9.0	42.0	41.9	41.7	41.7	41.6	41.5	41.4	41.3	41.3	38.8/9.3m	35.7/9.8m					9.0
10.0	35.8	35.7	35.5	35.5	35.4	35.2	35.2	35.0	35.0	34.9	34.7	28.0/10.4m	28.0/10.9m	28.0/11.4m		10.0
12.0	27.5	27.3	27.1	27.1	26.9	26.8	26.8	26.6	26.5	26.4	26.2	26.2	26.1	25.9	26.2	12.0
14.0	22.1	21.9	21.7	21.7	21.5	21.4	21.3	21.1	21.1	20.9	20.7	20.7	20.6	20.4	20.3	14.0
16.0	20.5/14.9m	18.2	18.0	17.9	17.7	17.6	17.5	17.3	17.3	17.1	16.9	16.9	16.7	16.6	16.4	16.0
18.0		16.2/17.5m	15.2	15.1	14.9	14.8	14.7	14.5	14.4	14.3	14.1	14.1	13.9	13.7	13.6	18.0
20.0			13.1	13.0	12.8	12.6	12.5	12.3	12.3	12.1	11.9	11.9	11.7	11.5	11.4	20.0
22.0			13.0/20.1m	11.3	11.1	10.9	10.8	10.6	10.6	10.4	10.2	10.2	10.0	9.8	9.6	22.0
24.0				10.8/22.8m	9.7	9.6	9.5	9.2	9.2	9.0	8.8	8.8	8.6	8.4	8.2	24.0
26.0					8.9/25.4m	8.5	8.3	8.1	8.0	7.9	7.6	7.6	7.4	7.2	7.1	26.0
28.0						7.5	7.4	7.1	7.1	6.9	6.7	6.6	6.5	6.3	6.1	28.0
30.0							6.6	6.3	6.2	6.1	5.8	5.8	5.6	5.4	5.3	30.0
32.0							6.4/30.7m	5.6	5.5	5.4	5.1	5.1	4.9	4.7	4.5	32.0
34.0								5.3/33.3m	4.9	4.8	4.5	4.5	4.3	4.1	3.9	34.0
36.0									4.4	4.2	4.0	3.9	3.8	3.5	3.3	36.0
38.0										3.8	3.5	3.4	3.2	2.9	2.7	38.0
40.0										3.6/38.6m	3.1	3.0	2.7	2.4	2.2	40.0
42.0											2.8/41.2m	2.5	2.3	2.0		42.0
44.0												2.1/43.9m				44.0

※表中の太線で囲まれた部分は、ブーム等の強度によって定められた値です。

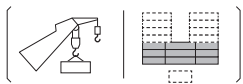

### 主ブーム定格総荷重表

(29.1tカウンタウイト[オプション] / 1枚または2枚補助シーブ付き / 軽量フック付き)

(単位：t)

作業半径 (m)	ブーム長さ (m)															作業半径 (m)
	15.2	18.3	21.3	24.4	27.4	30.5	33.5	36.6	39.6	42.7	45.7	48.8	51.8	54.9	57.9	
4.5	118.8															4.5
5.0	116.3	110.8/5.1m	93.8/5.6m													5.0
6.0	82.3	82.2	82.2	77.0/6.1m	66.3/6.7m											6.0
7.0	61.7	61.7	61.6	61.6	61.5	58.3/7.2m	51.3/7.7m									7.0
8.0	49.3	49.2	49.1	49.0	48.9	48.8	48.8	46.1/8.2m	40.8/8.8m							8.0
9.0	40.8	40.7	40.5	40.5	40.4	40.3	40.2	40.1	40.1	37.6/9.3m	34.5/9.8m					9.0
10.0	34.6	34.5	34.3	34.3	34.2	34.0	34.0	33.8	33.8	33.7	33.5	26.8/10.4m	26.8/10.9m	26.8/11.4m		10.0
12.0	26.3	26.1	25.9	25.9	25.7	25.6	25.6	25.4	25.3	25.2	25.0	25.0	24.9	24.7	25.0	12.0
14.0	20.9	20.7	20.5	20.5	20.3	20.2	20.1	19.9	19.9	19.7	19.5	19.5	19.4	19.2	19.1	14.0
16.0	19.3/14.9m	17.0	16.8	16.7	16.5	16.4	16.3	16.1	16.1	15.9	15.7	15.7	15.5	15.4	15.2	16.0
18.0		15.0/17.5m	14.0	13.9	13.7	13.6	13.5	13.3	13.2	13.1	12.9	12.9	12.7	12.5	12.4	18.0
20.0			11.9	11.8	11.6	11.4	11.3	11.1	11.1	10.9	10.7	10.7	10.5	10.3	10.2	20.0
22.0			11.8/20.1m	10.1	9.9	9.7	9.6	9.4	9.4	9.2	9.0	9.0	8.8	8.6	8.4	22.0
24.0				9.6/22.8m	8.5	8.4	8.3	8.0	8.0	7.8	7.6	7.6	7.4	7.2	7.0	24.0
26.0					7.7/25.4m	7.3	7.1	6.9	6.8	6.7	6.4	6.4	6.2	6.0	5.9	26.0
28.0						6.3	6.2	5.9	5.9	5.7	5.5	5.4	5.3	5.1	4.9	28.0
30.0							5.4	5.1	5.0	4.9	4.6	4.6	4.4	4.2	4.1	30.0
32.0							5.2/30.7m	4.4	4.3	4.2	3.9	3.9	3.7	3.5	3.3	32.0
34.0								4.1/33.3m	3.7	3.6	3.3	3.3	3.1	2.9	2.7	34.0
36.0									3.2	3.0	2.8	2.7	2.6	2.3	2.1	36.0
38.0										2.6	2.3	2.2	2.0			38.0
40.0										2.4/38.6m						40.0

※表中の太線で囲まれた部分は、ブーム等の強度によって定められた値です。

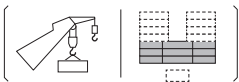

### 主ブーム定格総荷重表

(29.1tカウンタウエイト[オプション] / 1枚または2枚補助シーブ付き / ボールフック付き)

(単位：t)

作業半径 (m)	ブーム長さ (m)															作業半径 (m)
	15.2	18.3	21.3	24.4	27.4	30.5	33.5	36.6	39.6	42.7	45.7	48.8	51.8	54.9	57.9	
4.5	118.5															4.5
5.0	116.0	110.5/5.1m	93.5/5.6m													5.0
6.0	82.0	81.9	81.9	76.7/6.1m	66.0/6.7m											6.0
7.0	61.4	61.4	61.3	61.3	61.2	58.0/7.2m	51.0/7.7m									7.0
8.0	49.0	48.9	48.8	48.7	48.6	48.5	48.5	45.8/8.2m	40.5/8.8m							8.0
9.0	40.5	40.4	40.2	40.2	40.1	40.0	39.9	39.8	39.8	37.3/9.3m	34.2/9.8m					9.0
10.0	34.3	34.2	34.0	34.0	33.9	33.7	33.7	33.5	33.5	33.4	33.2	26.5/10.4m	26.5/10.9m	26.5/11.4m		10.0
12.0	26.0	25.8	25.6	25.6	25.4	25.3	25.3	25.1	25.0	24.9	24.7	24.7	24.6	24.4	24.7	12.0
14.0	20.6	20.4	20.2	20.2	20.0	19.9	19.8	19.6	19.6	19.4	19.2	19.2	19.1	18.9	18.8	14.0
16.0	19.0/14.9m	16.7	16.5	16.4	16.2	16.1	16.0	15.8	15.8	15.6	15.4	15.4	15.2	15.1	14.9	16.0
18.0		14.7/17.5m	13.7	13.6	13.4	13.3	13.2	13.0	12.9	12.8	12.6	12.6	12.4	12.2	12.1	18.0
20.0			11.6	11.5	11.3	11.1	11.0	10.8	10.8	10.6	10.4	10.4	10.2	10.0	9.9	20.0
22.0			11.5/20.1m	9.8	9.6	9.4	9.3	9.1	9.1	8.9	8.7	8.7	8.5	8.3	8.1	22.0
24.0				9.3/22.8m	8.2	8.1	8.0	7.7	7.7	7.5	7.3	7.3	7.1	6.9	6.7	24.0
26.0					7.4/25.4m	7.0	6.8	6.6	6.5	6.4	6.1	6.1	5.9	5.7	5.6	26.0
28.0						6.0	5.9	5.6	5.6	5.4	5.2	5.1	5.0	4.8	4.6	28.0
30.0							5.1	4.8	4.7	4.6	4.3	4.3	4.1	3.9	3.8	30.0
32.0							4.9/30.7m	4.1	4.0	3.9	3.6	3.6	3.4	3.2	3.0	32.0
34.0								3.8/33.3m	3.4	3.3	3.0	3.0	2.8	2.6	2.4	34.0
36.0									2.9	2.7	2.5	2.4	2.3	2.0		36.0
38.0										2.3	2.0					38.0
40.0										2.1/38.6m						40.0

※表中の太線で囲まれた部分は、ブーム等の強度によって定められた値です。

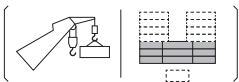

### 補助シーブ定格総荷重表

(29.1tカウンタウエイト[オプション] / 120tフック装着 / 1枚または2枚補助シーブ付き)

(単位：t)

作業半径 (m)	ブーム長さ (m)															作業半径 (m)
	15.2	18.3	21.3	24.4	27.4	30.5	33.5	36.6	39.6	42.7	45.7	48.8	51.8	54.9	57.9	
5.0	15.5/5.3m	15.5/5.8m														5.0
6.0	15.5	15.5	15.5/6.3m	15.5/6.9m												6.0
7.0	15.5	15.5	15.5	15.5	15.5/7.4m	15.5/7.9m										7.0
8.0	15.5	15.5	15.5	15.5	15.5	15.5	15.5	15.5/8.4m								8.0
9.0	15.5	15.5	15.5	15.5	15.5	15.5	15.5	15.5	15.5/9.5m							9.0
10.0	15.5	15.5	15.5	15.5	15.5	15.5	15.5	15.5	15.5	15.5	15.5	15.5	15.5/10.6m	15.5/11.1m	15.5/11.6m	10.0
12.0	15.5	15.5	15.5	15.5	15.5	15.5	15.5	15.5	15.5	15.5	15.5	15.5	15.5	15.5/12.2m	15.5/12.7m	12.0
14.0	15.5	15.5	15.5	15.5	15.5	15.5	15.5	15.5	15.5	15.5	15.5	15.5	15.5	15.5	15.5	14.0
16.0	14.4	15.5	15.5	15.5	15.4	15.3	15.2	15.0	15.0	14.8	14.6	14.6	14.4	14.3	14.1	16.0
18.0	13.9/16.2m	12.2	12.9	12.8	12.6	12.5	12.4	12.2	12.1	12.0	11.8	11.8	11.6	11.4	11.3	18.0
20.0		10.7/18.8m	10.8	10.7	10.5	10.3	10.2	10.0	10.0	9.8	9.6	9.6	9.4	9.2	9.1	20.0
22.0			9.2/21.5m	9.0	8.8	8.6	8.5	8.3	8.3	8.1	7.9	7.9	7.7	7.5	7.3	22.0
24.0				7.3	7.4	7.3	7.2	6.9	6.9	6.7	6.5	6.5	6.3	6.1	5.9	24.0
26.0				7.2/24.1m	6.0	6.2	6.0	5.8	5.7	5.6	5.3	5.3	5.1	4.9	4.8	26.0
28.0					5.5/26.7m	5.2	5.1	4.8	4.8	4.6	4.4	4.3	4.2	4.0	3.8	28.0
30.0						4.5/29.4m	4.3	4.0	3.9	3.8	3.5	3.5	3.3	3.1	3.0	30.0
32.0							3.5	3.3	3.2	3.1	2.8	2.8	2.6	2.4	2.2	32.0
34.0								2.6	2.6	2.5	2.2	2.2	2.0			34.0
36.0								2.4/34.7m	2.1							36.0

※表中の太線で囲まれた部分は、ブーム等の強度によって定められた値です。



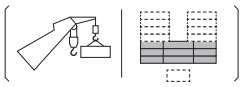

### ▶ 補助シーブ定格総荷重表

(29.1tカウンタウエイト[オプション]/70tフック装着/1枚または2枚補助シーブ付き)

(単位：t)

作業半径 (m)	ブーム長さ (m)															作業半径 (m)	
	15.2	18.3	21.3	24.4	27.4	30.5	33.5	36.6	39.6	42.7	45.7	48.8	51.8	54.9	57.9		
5.0	15.5/5.3m	15.5/5.8m															5.0
6.0	15.5	15.5	15.5/6.3m	15.5/6.9m													6.0
7.0	15.5	15.5	15.5	15.5	15.5/7.4m	15.5/7.9m											7.0
8.0	15.5	15.5	15.5	15.5	15.5	15.5	15.5/8.4m										8.0
9.0	15.5	15.5	15.5	15.5	15.5	15.5	15.5	15.5	15.5/9.5m								9.0
10.0	15.5	15.5	15.5	15.5	15.5	15.5	15.5	15.5	15.5	15.5	15.5/10.6m	15.5/11.1m	15.5/11.6m				10.0
12.0	15.5	15.5	15.5	15.5	15.5	15.5	15.5	15.5	15.5	15.5	15.5	15.5	15.5	15.5/12.2m	15.5/12.7m		12.0
14.0	15.5	15.5	15.5	15.5	15.5	15.5	15.5	15.5	15.5	15.5	15.5	15.5	15.5	15.5	15.5	15.5	14.0
16.0	15.0	15.5	15.5	15.5	15.5	15.5	15.5	15.5	15.5	15.5	15.4	15.2	15.2	15.0	14.9	14.7	16.0
18.0	14.5/16.2m	12.8	13.5	13.4	13.2	13.1	13.0	12.8	12.7	12.6	12.4	12.4	12.2	12.0	11.9		18.0
20.0		11.3/18.8m	11.4	11.3	11.1	10.9	10.8	10.6	10.6	10.4	10.2	10.2	10.0	9.8	9.7		20.0
22.0			9.8/21.5m	9.6	9.4	9.2	9.1	8.9	8.9	8.7	8.5	8.5	8.3	8.1	7.9		22.0
24.0				7.9	8.0	7.9	7.8	7.5	7.5	7.3	7.1	7.1	6.9	6.7	6.5		24.0
26.0				7.8/24.1m	6.6	6.8	6.6	6.4	6.3	6.2	5.9	5.9	5.7	5.5	5.4		26.0
28.0					6.1/26.7m	5.8	5.7	5.4	5.4	5.2	5.0	4.9	4.8	4.6	4.4		28.0
30.0						5.1/29.4m	4.9	4.6	4.5	4.4	4.1	4.1	3.9	3.7	3.6		30.0
32.0							4.1	3.9	3.8	3.7	3.4	3.4	3.2	3.0	2.8		32.0
34.0								3.2	3.2	3.1	2.8	2.8	2.6	2.4	2.2		34.0
36.0									3.0/34.7m	2.7	2.5	2.3	2.2	2.1			36.0
38.0										2.4/37.3m	2.1						38.0

※表中の太線で囲まれた部分は、ブーム等の強度によって定められた値です。

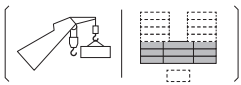

### ▶ 補助シーブ定格総荷重表

(29.1tカウンタウエイト[オプション]/50tフック装着/1枚または2枚補助シーブ付き)

(単位：t)

作業半径 (m)	ブーム長さ (m)															作業半径 (m)	
	15.2	18.3	21.3	24.4	27.4	30.5	33.5	36.6	39.6	42.7	45.7	48.8	51.8	54.9	57.9		
5.0	15.5/5.3m	15.5/5.8m															5.0
6.0	15.5	15.5	15.5/6.3m	15.5/6.9m													6.0
7.0	15.5	15.5	15.5	15.5	15.5/7.4m	15.5/7.9m											7.0
8.0	15.5	15.5	15.5	15.5	15.5	15.5	15.5/8.4m										8.0
9.0	15.5	15.5	15.5	15.5	15.5	15.5	15.5	15.5	15.5/9.5m								9.0
10.0	15.5	15.5	15.5	15.5	15.5	15.5	15.5	15.5	15.5	15.5	15.5/10.6m	15.5/11.1m	15.5/11.6m				10.0
12.0	15.5	15.5	15.5	15.5	15.5	15.5	15.5	15.5	15.5	15.5	15.5	15.5	15.5	15.5/12.2m	15.5/12.7m		12.0
14.0	15.5	15.5	15.5	15.5	15.5	15.5	15.5	15.5	15.5	15.5	15.5	15.5	15.5	15.5	15.5	15.5	14.0
16.0	15.3	15.5	15.5	15.5	15.5	15.5	15.5	15.5	15.5	15.5	15.5	15.5	15.5	15.3	15.2	15.0	16.0
18.0	14.8/16.2m	13.1	13.8	13.7	13.5	13.4	13.3	13.1	13.0	12.9	12.7	12.7	12.5	12.3	12.2		18.0
20.0		11.6/18.8m	11.7	11.6	11.4	11.2	11.1	10.9	10.9	10.7	10.5	10.5	10.3	10.1	10.0		20.0
22.0			10.1/21.5m	9.9	9.7	9.5	9.4	9.2	9.2	9.0	8.8	8.8	8.6	8.4	8.2		22.0
24.0				8.2	8.3	8.2	8.1	7.8	7.8	7.6	7.4	7.4	7.2	7.0	6.8		24.0
26.0				8.1/24.1m	6.9	7.1	6.9	6.7	6.6	6.5	6.2	6.2	6.0	5.8	5.7		26.0
28.0					6.4/26.7m	6.1	6.0	5.7	5.7	5.5	5.3	5.2	5.1	4.9	4.7		28.0
30.0						5.4/29.4m	5.2	4.9	4.8	4.7	4.4	4.4	4.2	4.0	3.9		30.0
32.0							4.4	4.2	4.1	4.0	3.7	3.7	3.5	3.3	3.1		32.0
34.0								3.5	3.5	3.4	3.1	3.1	2.9	2.7	2.5		34.0
36.0									3.3/34.7m	3.0	2.8	2.6	2.5	2.4	2.1		36.0
38.0											2.4	2.1	2.0				38.0
40.0												2.0/39.9m					40.0

※表中の太線で囲まれた部分は、ブーム等の強度によって定められた値です。

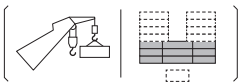

### ▶ 補助シーブ定格総荷重表

(29.1tカウンタウエイト[オプション]/35tフック装着/1枚または2枚補助シーブ付き)

(単位：t)

作業半径 (m)	ブーム長さ (m)															作業半径 (m)	
	15.2	18.3	21.3	24.4	27.4	30.5	33.5	36.6	39.6	42.7	45.7	48.8	51.8	54.9	57.9		
5.0	15.5/5.3m	15.5/5.8m															5.0
6.0	15.5	15.5	15.5/6.3m	15.5/6.9m													6.0
7.0	15.5	15.5	15.5	15.5	15.5/7.4m	15.5/7.9m											7.0
8.0	15.5	15.5	15.5	15.5	15.5	15.5	15.5/8.4m										8.0
9.0	15.5	15.5	15.5	15.5	15.5	15.5	15.5	15.5	15.5/9.5m								9.0
10.0	15.5	15.5	15.5	15.5	15.5	15.5	15.5	15.5	15.5	15.5	15.5/10.6m	15.5/11.1m	15.5/11.6m				10.0
12.0	15.5	15.5	15.5	15.5	15.5	15.5	15.5	15.5	15.5	15.5	15.5	15.5	15.5	15.5/12.2m	15.5/12.7m		12.0
14.0	15.5	15.5	15.5	15.5	15.5	15.5	15.5	15.5	15.5	15.5	15.5	15.5	15.5	15.5	15.5	15.5	14.0
16.0	15.5	15.5	15.5	15.5	15.5	15.5	15.5	15.5	15.5	15.5	15.5	15.5	15.5	15.5	15.4	15.2	16.0
18.0	15.0/16.2m	13.3	14.0	13.9	13.7	13.6	13.5	13.3	13.2	13.1	12.9	12.9	12.7	12.5	12.4		18.0
20.0		11.8/18.8m	11.9	11.8	11.6	11.4	11.3	11.1	11.1	10.9	10.7	10.7	10.5	10.3	10.2		20.0
22.0			10.3/21.5m	10.1	9.9	9.7	9.6	9.4	9.4	9.2	9.0	9.0	8.8	8.6	8.4		22.0
24.0				8.4	8.5	8.4	8.3	8.0	8.0	7.8	7.6	7.6	7.4	7.2	7.0		24.0
26.0				8.3/24.1m	7.1	7.3	7.1	6.9	6.8	6.7	6.4	6.4	6.2	6.0	5.9		26.0
28.0					6.6/26.7m	6.3	6.2	5.9	5.9	5.7	5.5	5.4	5.3	5.1	4.9		28.0
30.0						5.6/29.4m	5.4	5.1	5.0	4.9	4.6	4.6	4.4	4.2	4.1		30.0
32.0							4.6	4.4	4.3	4.2	3.9	3.9	3.7	3.5	3.3		32.0
34.0								3.7	3.7	3.6	3.3	3.3	3.1	2.9	2.7		34.0
36.0								3.5/34.7m	3.2	3.0	2.8	2.7	2.6	2.3	2.1		36.0
38.0									2.9/37.3m	2.6	2.3	2.2	2.0				38.0
40.0										2.2/39.9m							40.0

※表中の太線で囲まれた部分は、ブーム等の強度によって定められた値です。

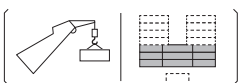

### ▶ 補助シーブ定格総荷重表

(29.1tカウンタウエイト[オプション]/主ブームにフックなし/1枚または2枚補助シーブ付き)

(単位：t)

作業半径 (m)	ブーム長さ (m)															作業半径 (m)	
	15.2	18.3	21.3	24.4	27.4	30.5	33.5	36.6	39.6	42.7	45.7	48.8	51.8	54.9	57.9		
5.0	15.5/5.3m	15.5/5.8m															5.0
6.0	15.5	15.5	15.5/6.3m	15.5/6.9m													6.0
7.0	15.5	15.5	15.5	15.5	15.5/7.4m	15.5/7.9m											7.0
8.0	15.5	15.5	15.5	15.5	15.5	15.5	15.5/8.4m	15.5									8.0
9.0	15.5	15.5	15.5	15.5	15.5	15.5	15.5	15.5	15.5/9.5m								9.0
10.0	15.5	15.5	15.5	15.5	15.5	15.5	15.5	15.5	15.5	15.5	15.5/10.6m	15.5/11.1m	15.5/11.6m				10.0
12.0	15.5	15.5	15.5	15.5	15.5	15.5	15.5	15.5	15.5	15.5	15.5	15.5	15.5	15.5/12.2m	15.5/12.7m		12.0
14.0	15.5	15.5	15.5	15.5	15.5	15.5	15.5	15.5	15.5	15.5	15.5	15.5	15.5	15.5	15.5	15.5	14.0
16.0	15.5	15.5	15.5	15.5	15.5	15.5	15.5	15.5	15.5	15.5	15.5	15.5	15.5	15.5	15.5	15.5	16.0
18.0	15.5/16.2m	14.0	14.7	14.6	14.4	14.3	14.2	14.0	13.9	13.8	13.6	13.6	13.4	13.2	13.1		18.0
20.0		12.5/18.8m	12.6	12.5	12.3	12.1	12.0	11.8	11.8	11.6	11.4	11.4	11.2	11.0	10.9		20.0
22.0			11.0/21.5m	10.8	10.6	10.4	10.3	10.1	10.1	9.9	9.7	9.7	9.5	9.3	9.1		22.0
24.0				9.1	9.2	9.1	9.0	8.7	8.7	8.5	8.3	8.3	8.1	7.9	7.7		24.0
26.0				9.0/24.1m	7.8	8.0	7.8	7.6	7.5	7.4	7.1	7.1	6.9	6.7	6.6		26.0
28.0					7.3/26.7m	7.0	6.9	6.6	6.6	6.4	6.2	6.1	6.0	5.8	5.6		28.0
30.0						6.3/29.4m	6.1	5.8	5.7	5.6	5.3	5.3	5.1	4.9	4.8		30.0
32.0							5.3	5.1	5.0	4.9	4.6	4.6	4.4	4.2	4.0		32.0
34.0								4.4	4.4	4.3	4.0	4.0	3.8	3.6	3.4		34.0
36.0								4.2/34.7m	3.9	3.7	3.5	3.4	3.3	3.0	2.8		36.0
38.0									3.6/37.3m	3.3	3.0	2.9	2.7	2.4	2.2		38.0
40.0										2.9/39.9m	2.6	2.5	2.2				40.0
42.0											2.2	2.0					42.0
44.0												2.1/42.6m					44.0

※表中の太線で囲まれた部分は、ブーム等の強度によって定められた値です。

## ▶ サードドラム (オプション)

- 基本的な注意事項は、P5 の定格総荷重と同様です。
- フックのロープ掛数は、下表を守ってください。異なったロープ掛数にしますと、フックの巻上操作を行ったとき、ブームが起きブームが後方に転倒します。
- サードロープの1本掛は使用しないでください。

- サードドラムロープ巻掛数による最大巻上荷重とフックの質量

フック呼称	最大巻上荷重 (t)										フック質量
	1本掛	2本掛	3本掛	4本掛	5本掛	6本掛	7本掛	8本掛	9本掛	10本掛	
120t	—	—	—	48.0	60.0	72.0	84.0	96.0	108.0	120.0	1.80t
70t (両カギ)	—	24.0	36.0	48.0	60.0	70.0	—	—	—	—	1.20t
70t (片カギ)	—	24.0	36.0	48.0	60.0	70.0	—	—	—	—	0.93t
50t	—	24.0	36.0	48.0	50.0	—	—	—	—	—	0.85t
35t	—	24.0	35.0	—	—	—	—	—	—	—	0.70t

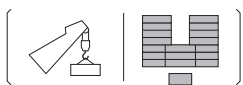

## ▶ 主ブーム定格総荷重表・サードドラム使用 (59.1tカウンタウエイト / 補助シーブなし)

(単位：t)

作業半径 (m)	ブーム長さ (m)															作業半径 (m)	
	15.2	18.3	21.3	24.4	27.4	30.5	33.5	36.6	39.6	42.7	45.7	48.8	51.8	54.9	57.9		61.0
4.5	120.0																4.5
5.0	120.0	116.6/5.1m	108.0/5.6m														5.0
6.0	110.4	110.1	108.0	98.9/6.1m	87.6/6.7m												6.0
7.0	95.1	94.6	93.0	90.9	86.4	78.3/7.2m	70.2/7.7m										7.0
8.0	79.4	79.7	78.7	77.2	75.6	74.4	69.6	60.0/8.2m	57.4/8.8m								8.0
9.0	67.6	68.6	68.1	67.0	65.7	64.6	62.5	60.0	57.0	48.0/9.3m	46.8/9.8m						9.0
10.0	58.2	58.8	58.6	58.5	58.1	57.1	56.2	55.0	53.6	48.0	46.6	42.8/10.4m	36.0/10.9m	34.7/11.4m			10.0
12.0	44.1	45.6	45.4	45.2	45.1	45.0	44.9	44.8	44.0	43.0	42.0	41.0	36.0	34.2	31.8	29.1/12.5m	12.0
14.0	33.3	37.0	36.8	36.7	36.5	36.4	36.3	36.2	36.1	36.0	35.6	34.7	33.9	32.6	30.3	27.9	14.0
16.0	29.1/14.9m	29.8	30.9	30.7	30.5	30.4	30.3	30.2	30.0	30.0	29.8	29.6	29.3	28.7	28.3	26.2	16.0
18.0		24.6/17.5m	26.5	26.3	26.1	26.0	25.9	25.7	25.6	25.5	25.3	25.1	25.1	24.9	24.6	24.0	18.0
20.0			21.3	22.9	22.7	22.6	22.5	22.3	22.2	22.1	21.9	21.7	21.7	21.5	21.3	21.1	20.0
22.0			21.0/20.1m	19.7	20.0	19.9	19.8	19.6	19.5	19.4	19.1	19.0	18.9	18.7	18.6	18.4	22.0
24.0				18.2/22.8m	17.9	17.7	17.6	17.4	17.3	17.2	16.9	16.8	16.7	16.5	16.4	16.2	24.0
26.0					15.8/25.4m	16.0	15.8	15.6	15.5	15.3	15.1	15.0	14.9	14.7	14.5	14.3	26.0
28.0						13.9	14.3	14.1	14.0	13.8	13.6	13.5	13.4	13.2	13.0	12.8	28.0
30.0							12.9	12.8	12.7	12.5	12.3	12.2	12.1	11.9	11.7	11.5	30.0
32.0							12.2/30.7m	11.7	11.6	11.4	11.2	11.0	10.9	10.7	10.6	10.3	32.0
34.0								10.7/33.3m	10.6	10.4	10.2	10.1	10.0	9.7	9.6	9.3	34.0
36.0									9.4	9.6	9.3	9.2	9.1	8.9	8.7	8.5	36.0
38.0										8.7	8.6	8.4	8.3	8.1	7.9	7.7	38.0
40.0											8.3/38.6m	7.8	7.8	7.7	7.4	7.0	40.0
42.0												7.2/41.2m	7.1	7.1	6.8	6.4	42.0
44.0													6.2/43.9m	6.4	6.3	6.1	44.0
46.0														5.6	5.7	5.3	46.0
48.0														5.4/46.5m	5.0	4.8	48.0
50.0															4.5/49.2m	4.4	50.0
52.0																3.8/51.8m	52.0
54.0																	54.0
56.0																	56.0

※表中の太線で囲まれた部分は、ブーム等の強度によって定められた値です。

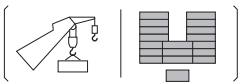

▶ **主ブーム定格総荷重表・サードドラム使用**  
 (59.1tカウンタウエイト / 1枚または2枚補助シーブ付き / 軽量フック付き)

(単位: t)

作業半径 (m)	ブーム長さ (m)															作業半径 (m)	
	15.2	18.3	21.3	24.4	27.4	30.5	33.5	36.6	39.6	42.7	45.7	48.8	51.8	54.9	57.9		61.0
4.5	118.8																4.5
5.0	118.8	115.4/5.1m	106.8/5.6m														5.0
6.0	109.2	108.9	106.8	97.7/6.1m	86.4/6.7m												6.0
7.0	93.9	93.4	91.8	89.7	85.2	77.1/7.2m	69.0/7.7m										7.0
8.0	78.2	78.5	77.5	76.0	74.4	73.2	68.4	58.8/8.2m	56.2/8.8m								8.0
9.0	66.4	67.4	66.9	65.8	64.5	63.4	61.3	58.8	55.8	46.8/9.3m	45.6/9.8m						9.0
10.0	57.0	57.6	57.4	57.3	56.9	55.9	55.0	53.8	52.4	46.8	45.4	41.6/10.4m	34.8/10.9m	33.5/11.4m			10.0
12.0	42.9	44.4	44.2	44.0	43.9	43.8	43.7	43.6	42.8	41.8	40.8	39.8	34.8	33.0	30.6	27.9/12.5m	12.0
14.0	32.1	35.8	35.6	35.5	35.3	35.2	35.1	35.0	34.9	34.8	34.4	33.5	32.7	31.4	29.1	26.7	14.0
16.0	27.9/14.9m	28.6	29.7	29.5	29.3	29.2	29.1	29.0	28.8	28.8	28.6	28.4	28.1	27.5	27.1	25.0	16.0
18.0		23.4/17.5m	25.3	25.1	24.9	24.8	24.7	24.5	24.4	24.3	24.1	23.9	23.9	23.7	23.4	22.8	18.0
20.0			20.1	21.7	21.5	21.4	21.3	21.1	21.0	20.9	20.7	20.5	20.3	20.1	19.9	20.0	20.0
22.0			19.8/20.1m	18.5	18.8	18.7	18.6	18.4	18.3	18.2	17.9	17.8	17.7	17.5	17.4	17.2	22.0
24.0				17.0/22.8m	16.7	16.5	16.4	16.2	16.1	16.0	15.7	15.6	15.5	15.3	15.2	15.0	24.0
26.0					14.6/25.4m	14.8	14.6	14.4	14.3	14.1	13.9	13.8	13.7	13.5	13.3	13.1	26.0
28.0						12.7	13.1	12.9	12.8	12.6	12.4	12.3	12.2	12.0	11.8	11.6	28.0
30.0							11.7	11.6	11.5	11.3	11.1	11.0	10.9	10.7	10.5	10.3	30.0
32.0							11.0/30.7m	10.5	10.4	10.2	10.0	9.8	9.7	9.5	9.4	9.1	32.0
34.0								9.5/33.3m	9.4	9.2	9.0	8.9	8.8	8.5	8.4	8.1	34.0
36.0									8.2	8.4	8.1	8.0	7.9	7.7	7.5	7.3	36.0
38.0										7.5	7.4	7.2	7.1	6.9	6.7	6.5	38.0
40.0										7.1/38.6m	6.6	6.6	6.5	6.2	6.1	5.8	40.0
42.0											6.0/41.2m	5.9	5.9	5.6	5.4	5.2	42.0
44.0												5.0/43.9m	5.2	5.1	4.9	4.7	44.0
46.0													4.4	4.5	4.4	4.1	46.0
48.0													4.2/46.5m	3.8	3.8	3.6	48.0
50.0														3.3/49.2m	3.2	3.1	50.0
52.0															2.6/51.8m	2.6	52.0
54.0																2.0	54.0

※表中の太線で囲まれた部分は、ブーム等の強度によって定められた値です。

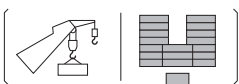

▶ **主ブーム定格総荷重表・サードドラム使用**  
 (59.1tカウンタウエイト / 1枚または2枚補助シーブ付き / ボールフック付き)

(単位: t)

作業半径 (m)	ブーム長さ (m)															作業半径 (m)	
	15.2	18.3	21.3	24.4	27.4	30.5	33.5	36.6	39.6	42.7	45.7	48.8	51.8	54.9	57.9		61.0
4.5	118.5																4.5
5.0	118.5	115.1/5.1m	106.5/5.6m														5.0
6.0	108.9	108.6	106.5	97.4/6.1m	86.1/6.7m												6.0
7.0	93.6	93.1	91.5	89.4	84.9	76.8/7.2m	68.7/7.7m										7.0
8.0	77.9	78.2	77.2	75.7	74.1	72.9	68.1	58.5/8.2m	55.9/8.8m								8.0
9.0	66.1	67.1	66.6	65.5	64.2	63.1	61.0	58.5	55.5	46.5/9.3m	45.3/9.8m						9.0
10.0	56.7	57.3	57.1	57.0	56.6	55.6	54.7	53.5	52.1	46.5	45.1	41.3/10.4m	34.5/10.9m	33.2/11.4m			10.0
12.0	42.6	44.1	43.9	43.7	43.6	43.5	43.4	43.3	42.5	41.5	40.5	39.5	34.5	32.7	30.3	27.6/12.5m	12.0
14.0	31.8	35.5	35.3	35.2	35.0	34.9	34.8	34.7	34.6	34.5	34.1	33.2	32.4	31.1	28.8	26.4	14.0
16.0	27.6/14.9m	28.3	29.4	29.2	29.0	28.9	28.8	28.7	28.5	28.5	28.3	28.1	27.8	27.2	26.8	24.7	16.0
18.0		23.1/17.5m	25.0	24.8	24.6	24.5	24.4	24.2	24.1	24.0	23.8	23.6	23.6	23.4	23.1	22.5	18.0
20.0			19.8	21.4	21.2	21.1	21.0	20.8	20.7	20.6	20.4	20.2	20.2	20.0	19.8	19.6	20.0
22.0			19.5/20.1m	18.2	18.5	18.4	18.3	18.1	18.0	17.9	17.6	17.5	17.4	17.2	17.1	16.9	22.0
24.0				16.7/22.8m	16.4	16.2	16.1	15.9	15.8	15.7	15.4	15.3	15.2	15.0	14.9	14.7	24.0
26.0					14.3/25.4m	14.5	14.3	14.1	14.0	13.8	13.6	13.5	13.4	13.2	13.0	12.8	26.0
28.0						12.4	12.8	12.6	12.5	12.3	12.1	12.0	11.9	11.7	11.5	11.3	28.0
30.0							11.4	11.3	11.2	11.0	10.8	10.7	10.6	10.4	10.2	10.0	30.0
32.0							10.7/30.7m	10.2	10.1	9.9	9.7	9.5	9.4	9.2	9.1	8.8	32.0
34.0								9.2/33.3m	9.1	8.9	8.7	8.6	8.5	8.2	8.1	7.8	34.0
36.0									7.9	8.1	7.8	7.7	7.6	7.4	7.2	7.0	36.0
38.0										7.2	7.1	6.9	6.8	6.6	6.4	6.2	38.0
40.0										6.8/38.6m	6.3	6.3	6.2	5.9	5.8	5.5	40.0
42.0											5.7/41.2m	5.6	5.6	5.3	5.1	4.9	42.0
44.0												4.7/43.9m	4.9	4.8	4.6	4.4	44.0
46.0													4.1	4.2	4.1	3.8	46.0
48.0													3.9/46.5m	3.5	3.5	3.3	48.0
50.0														3.0/49.2m	2.9	2.8	50.0
52.0															2.3/51.8m	2.3	52.0

※表中の太線で囲まれた部分は、ブーム等の強度によって定められた値です。

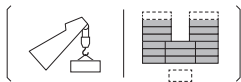

▶ **主ブーム定格総荷重表・サードドラム使用**  
(53.1tカウンタウイト[オプション]/補助シーブなし)

(単位：t)

作業半径 (m)	ブーム長さ (m)															作業半径 (m)	
	15.2	18.3	21.3	24.4	27.4	30.5	33.5	36.6	39.6	42.7	45.7	48.8	51.8	54.9	57.9		61.0
4.5	120.0																4.5
5.0	120.0	116.6/5.1m	108.0/5.6m														5.0
6.0	110.4	110.1	108.0	98.9/6.1m	87.6/6.7m												6.0
7.0	90.3	90.2	90.1	90.0	86.4	78.3/7.2m	70.2/7.7m										7.0
8.0	72.8	72.6	72.5	72.4	72.3	72.2	69.6	60.0/8.2m	57.4/8.8m								8.0
9.0	60.8	60.6	60.5	60.4	60.2	60.2	60.1	60.0	57.0	48.0/9.3m	46.8/9.8m						9.0
10.0	52.1	52.0	51.8	51.7	51.5	51.5	51.4	51.3	51.2	48.0	46.6	42.8/10.4m	36.0/10.9m	34.7/11.4m			10.0
12.0	40.4	40.2	40.0	39.9	39.7	39.6	39.5	39.4	39.3	39.2	39.0	38.9	36.0	34.2	31.8	29.1/12.5m	12.0
14.0	32.8	32.6	32.4	32.3	32.1	32.0	31.9	31.8	31.6	31.6	31.4	31.2	31.2	31.0	30.2	27.9	14.0
16.0	29.1/14.9m	27.3	27.1	26.9	26.7	26.7	26.6	26.4	26.3	26.2	26.0	25.8	25.8	25.6	25.4	25.3	16.0
18.0		24.3/17.5m	23.2	23.0	22.8	22.7	22.6	22.5	22.3	22.2	22.0	21.9	21.8	21.6	21.5	21.3	18.0
20.0			20.2	20.0	19.8	19.7	19.6	19.4	19.3	19.2	19.0	18.8	18.8	18.6	18.4	18.2	20.0
22.0			20.1/20.1m	17.7	17.4	17.3	17.2	17.0	16.9	16.8	16.6	16.4	16.4	16.1	16.0	15.8	22.0
24.0				16.9/22.8m	15.5	15.4	15.3	15.1	14.9	14.8	14.6	14.5	14.4	14.2	14.0	13.8	24.0
26.0					14.4/25.4m	13.8	13.7	13.5	13.3	13.2	13.0	12.8	12.8	12.6	12.4	12.2	26.0
28.0						12.5	12.3	12.1	12.0	11.9	11.6	11.5	11.4	11.2	11.0	10.8	28.0
30.0							11.2	11.0	10.8	10.7	10.5	10.3	10.2	10.0	9.9	9.6	30.0
32.0							10.9/30.7m	10.0	9.8	9.7	9.5	9.3	9.2	9.0	8.8	8.6	32.0
34.0								9.5/33.3m	9.0	8.9	8.6	8.5	8.4	8.1	8.0	7.7	34.0
36.0									8.3	8.1	7.9	7.7	7.6	7.4	7.2	7.0	36.0
38.0										7.4	7.2	7.0	6.9	6.7	6.5	6.3	38.0
40.0										7.3/38.6m	6.6	6.4	6.3	6.1	5.9	5.7	40.0
42.0											6.3/41.2m	5.9	5.8	5.6	5.4	5.1	42.0
44.0												5.5/43.9m	5.3	5.1	4.8	4.5	44.0
46.0													4.9	4.6	4.3	4.0	46.0
48.0													4.8/46.5m	4.1	3.9	3.5	48.0
50.0														3.9/49.2m	3.5	3.1	50.0
52.0															3.1/51.8m	2.8	52.0
54.0																2.4	54.0
56.0																2.3/54.4m	56.0

※表中の太線で囲まれた部分は、ブーム等の強度によって定められた値です。

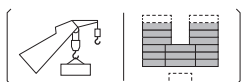

▶ **主ブーム定格総荷重表・サードドラム使用**  
(53.1tカウンタウイト[オプション]/1枚または2枚補助シーブ付き/軽量フック付き)

(単位：t)

作業半径 (m)	ブーム長さ (m)															作業半径 (m)	
	15.2	18.3	21.3	24.4	27.4	30.5	33.5	36.6	39.6	42.7	45.7	48.8	51.8	54.9	57.9		61.0
4.5	118.8																4.5
5.0	118.8	115.4/5.1m	106.8/5.6m														5.0
6.0	109.2	108.9	106.8	97.7/6.1m	86.4/6.7m												6.0
7.0	89.1	89.0	88.9	88.8	85.2	77.1/7.2m	69.0/7.7m										7.0
8.0	71.6	71.4	71.3	71.2	71.1	71.0	68.4	58.8/8.2m	56.2/8.8m								8.0
9.0	59.6	59.4	59.3	59.2	59.0	59.0	58.9	58.8	55.8	46.8/9.3m	45.6/9.8m						9.0
10.0	50.9	50.8	50.6	50.5	50.3	50.3	50.2	50.1	50.0	46.8	45.4	41.6/10.4m	34.8/10.9m	33.5/11.4m			10.0
12.0	39.2	39.0	38.8	38.7	38.5	38.4	38.3	38.2	38.1	38.0	37.8	37.7	34.8	33.0	30.6	27.9/12.5m	12.0
14.0	31.6	31.4	31.2	31.1	30.9	30.8	30.7	30.6	30.4	30.4	30.2	30.0	30.0	29.8	29.0	26.7	14.0
16.0	27.9/14.9m	26.1	25.9	25.7	25.5	25.4	25.2	25.1	25.0	24.8	24.6	24.6	24.4	24.2	24.1	24.1	16.0
18.0		23.1/17.5m	22.0	21.8	21.6	21.5	21.4	21.3	21.1	21.0	20.8	20.7	20.6	20.4	20.3	20.1	18.0
20.0			19.0	18.8	18.6	18.5	18.4	18.2	18.1	18.0	17.8	17.6	17.6	17.4	17.2	17.0	20.0
22.0			18.9/20.1m	16.5	16.2	16.1	16.0	15.8	15.7	15.6	15.4	15.2	15.2	14.9	14.8	14.6	22.0
24.0				15.7/22.8m	14.3	14.2	14.1	13.9	13.7	13.6	13.4	13.3	13.2	13.0	12.8	12.6	24.0
26.0					13.2/25.4m	12.6	12.5	12.3	12.1	12.0	11.8	11.6	11.6	11.4	11.2	11.0	26.0
28.0						11.3	11.1	10.9	10.8	10.7	10.4	10.3	10.2	10.0	9.8	9.6	28.0
30.0							10.0	9.8	9.6	9.5	9.3	9.1	9.0	8.8	8.7	8.4	30.0
32.0							9.7/30.7m	8.8	8.6	8.5	8.3	8.1	8.0	7.8	7.6	7.4	32.0
34.0								8.3/33.3m	7.8	7.7	7.4	7.3	7.2	6.9	6.8	6.5	34.0
36.0									7.1	6.9	6.7	6.5	6.4	6.2	6.0	5.8	36.0
38.0										6.2	6.0	5.8	5.7	5.5	5.3	5.1	38.0
40.0										6.1/38.6m	5.4	5.2	5.1	4.9	4.7	4.5	40.0
42.0											5.1/41.2m	4.7	4.6	4.4	4.2	3.9	42.0
44.0												4.3/43.9m	4.1	3.9	3.6	3.3	44.0
46.0													3.7	3.4	3.1	2.8	46.0
48.0													3.6/46.5m	2.9	2.7	2.3	48.0
50.0														2.7/49.2m	2.3		50.0

※表中の太線で囲まれた部分は、ブーム等の強度によって定められた値です。

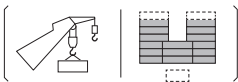

主ブーム定格総荷重表・サードドラム使用  
(53.1tカウンタウエイト[オプション] / 1枚または2枚補助シーブ付き / ボールフック付き)

(単位：t)

作業半径 (m)	ブーム長さ (m)															作業半径 (m)	
	15.2	18.3	21.3	24.4	27.4	30.5	33.5	36.6	39.6	42.7	45.7	48.8	51.8	54.9	57.9		61.0
4.5	118.5																4.5
5.0	118.5	115.1/5.1m	106.5/5.6m														5.0
6.0	108.9	108.6	106.5	97.4/6.1m	86.1/6.7m												6.0
7.0	88.8	88.7	88.6	88.5	84.9	76.8/7.2m	68.7/7.7m										7.0
8.0	71.3	71.1	71.0	70.9	70.8	70.7	68.1	58.5/8.2m	55.9/8.8m								8.0
9.0	59.3	59.1	59.0	58.9	58.7	58.7	58.6	58.5	55.5	46.5/9.3m	45.3/9.8m						9.0
10.0	50.6	50.5	50.3	50.2	50.0	50.0	49.9	49.8	49.7	46.5	45.1	41.3/10.4m	34.5/10.9m	33.2/11.4m			10.0
12.0	38.9	38.7	38.5	38.4	38.2	38.1	38.0	37.9	37.8	37.7	37.5	37.4	34.5	32.7	30.3	27.6/12.5m	12.0
14.0	31.3	31.1	30.9	30.8	30.6	30.5	30.4	30.3	30.1	30.1	29.9	29.7	29.7	29.5	28.7	26.4	14.0
16.0	27.6/14.9m	25.8	25.6	25.4	25.2	25.2	25.1	24.9	24.8	24.7	24.5	24.3	24.3	24.1	23.9	23.8	16.0
18.0		22.8/17.5m	21.7	21.5	21.3	21.2	21.1	21.0	20.8	20.7	20.5	20.4	20.3	20.1	20.0	19.8	18.0
20.0			18.7	18.5	18.3	18.2	18.1	17.9	17.8	17.7	17.5	17.3	17.1	16.9	16.7	16.7	20.0
22.0			18.6/20.1m	16.2	15.9	15.8	15.7	15.5	15.4	15.3	15.1	14.9	14.9	14.6	14.5	14.3	22.0
24.0				15.4/22.8m	14.0	13.9	13.8	13.6	13.4	13.3	13.1	13.0	12.9	12.7	12.5	12.3	24.0
26.0					12.9/25.4m	12.3	12.2	12.0	11.8	11.7	11.5	11.3	11.3	11.1	10.9	10.7	26.0
28.0						11.0	10.8	10.6	10.5	10.4	10.1	10.0	9.9	9.7	9.5	9.3	28.0
30.0							9.7	9.5	9.3	9.2	9.0	8.8	8.7	8.5	8.4	8.1	30.0
32.0							9.4/30.7m	8.5	8.3	8.2	8.0	7.8	7.7	7.5	7.3	7.1	32.0
34.0								8.0/33.3m	7.5	7.4	7.1	7.0	6.9	6.6	6.5	6.2	34.0
36.0									6.8	6.6	6.4	6.2	6.1	5.9	5.7	5.5	36.0
38.0										5.9	5.7	5.5	5.4	5.2	5.0	4.8	38.0
40.0										5.8/38.6m	5.1	4.9	4.8	4.6	4.4	4.2	40.0
42.0											4.8/41.2m	4.4	4.3	4.1	3.9	3.6	42.0
44.0												4.0/43.9m	3.8	3.6	3.3	3.0	44.0
46.0													3.4	3.1	2.8	2.5	46.0
48.0													3.3/46.5m	2.6	2.4	2.0	48.0
50.0														2.4/49.2m	2.0		50.0

※表中の太線で囲まれた部分は、ブーム等の強度によって定められた値です。

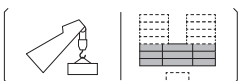

主ブーム定格総荷重表・サードドラム使用  
(29.1tカウンタウエイト[オプション] / 補助シーブなし)

(単位：t)

作業半径 (m)	ブーム長さ (m)															作業半径 (m)	
	15.2	18.3	21.3	24.4	27.4	30.5	33.5	36.6	39.6	42.7	45.7	48.8	51.8	54.9	57.9		
4.5	120.0																4.5
5.0	117.5	115.1/5.1m	95.0/5.6m														5.0
6.0	83.5	83.5	83.4	78.1/6.1m	67.4/6.7m												6.0
7.0	63.0	62.9	62.8	62.7	62.6	59.5/7.2m	52.4/7.7m										7.0
8.0	50.6	50.4	50.3	50.2	50.1	50.0	50.0	47.4/8.2m	42.6/8.8m								8.0
9.0	42.1	41.9	41.7	41.6	41.5	41.5	41.4	41.3	41.2	38.8/9.3m	35.7/9.8m						9.0
10.0	35.9	35.7	35.6	35.4	35.3	35.2	35.2	35.1	34.9	34.9	34.7	33.0/10.4m	30.0/10.9m	28.1/11.4m			10.0
12.0	27.5	27.3	27.2	27.0	26.9	26.8	26.7	26.6	26.5	26.4	26.2	26.1	26.0	25.9	25.9	26.2	12.0
14.0	22.2	22.0	21.8	21.6	21.4	21.4	21.3	21.1	21.0	20.9	20.7	20.6	20.5	20.4	20.2	20.2	14.0
16.0	20.6/14.9m	18.2	18.0	17.8	17.6	17.6	17.5	17.3	17.2	17.1	16.9	16.8	16.6	16.5	16.4	16.4	16.0
18.0		16.2/17.5m	15.2	15.1	14.9	14.8	14.7	14.5	14.4	14.3	14.1	13.9	13.8	13.7	13.5	13.5	18.0
20.0			13.1	12.9	12.7	12.6	12.5	12.4	12.2	12.1	11.9	11.8	11.6	11.5	11.4	11.4	20.0
22.0			13.1/20.1m	11.3	11.0	10.9	10.8	10.6	10.5	10.4	10.2	10.0	9.9	9.8	9.6	9.6	22.0
24.0				10.8/22.8m	9.7	9.6	9.4	9.3	9.1	9.0	8.8	8.6	8.5	8.4	8.2	8.2	24.0
26.0					8.9/25.4m	8.4	8.3	8.1	8.0	7.9	7.7	7.5	7.3	7.2	7.1	7.1	26.0
28.0						7.5	7.4	7.2	7.0	6.9	6.7	6.5	6.4	6.2	6.1	6.1	28.0
30.0							6.6	6.4	6.2	6.1	5.9	5.7	5.5	5.4	5.2	5.2	30.0
32.0							6.4/30.7m	5.7	5.5	5.4	5.2	5.0	4.8	4.7	4.5	4.5	32.0
34.0								5.3/33.3m	4.9	4.8	4.5	4.4	4.2	4.1	3.9	3.9	34.0
36.0									4.4/36.0m	4.2	4.0	3.8	3.7	3.5	3.2	3.2	36.0
38.0										3.8	3.5	3.4	3.1	2.9	2.7	2.7	38.0
40.0										3.7/38.6m	3.1	2.9	2.6	2.4	2.2	2.2	40.0
42.0											2.8/41.2m	2.5	2.2	2.0			42.0
44.0												2.1/43.9m					44.0

※表中の太線で囲まれた部分は、ブーム等の強度によって定められた値です。

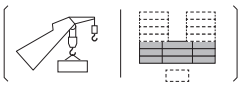

### ▶ 主ブーム定格総荷重表・サードドラム使用

(29.1tカウンタウエイト[オプション] / 1枚または2枚補助シーブ付き / 軽量フック付き)

(単位：t)

作業半径 (m)	ブーム長さ (m)															作業半径 (m)
	15.2	18.3	21.3	24.4	27.4	30.5	33.5	36.6	39.6	42.7	45.7	48.8	51.8	54.9	57.9	
4.5	118.8															4.5
5.0	116.3	113.9/5.1m	93.8/5.6m													5.0
6.0	82.3	82.3	82.2	76.9/6.1m	66.2/6.7m											6.0
7.0	61.8	61.7	61.6	61.5	61.4	58.3/7.2m	51.2/7.7m									7.0
8.0	49.4	49.2	49.1	49.0	48.9	48.8	48.8	46.2/8.2m	41.4/8.8m							8.0
9.0	40.9	40.7	40.5	40.4	40.3	40.3	40.2	40.1	40.0	37.6/9.3m	34.5/9.8m					9.0
10.0	34.7	34.5	34.4	34.2	34.1	34.0	34.0	33.9	33.7	33.7	33.5	31.8/10.4m	28.8/10.9m	26.9/11.4m		10.0
12.0	26.3	26.1	26.0	25.8	25.7	25.6	25.5	25.4	25.3	25.2	25.0	24.9	24.8	24.7	25.0	12.0
14.0	21.0	20.8	20.6	20.4	20.2	20.2	20.1	19.9	19.8	19.7	19.5	19.4	19.3	19.2	19.0	14.0
16.0	19.4/14.9m	17.0	16.8	16.6	16.4	16.4	16.3	16.1	16.0	15.9	15.7	15.6	15.4	15.3	15.2	16.0
18.0		15.0/17.5m	14.0	13.9	13.7	13.6	13.5	13.3	13.2	13.1	12.9	12.7	12.6	12.5	12.3	18.0
20.0			11.9	11.7	11.5	11.4	11.3	11.2	11.0	10.9	10.7	10.6	10.4	10.3	10.2	20.0
22.0			11.9/20.1m	10.1	9.8	9.7	9.6	9.4	9.3	9.2	9.0	8.8	8.7	8.6	8.4	22.0
24.0				9.6/22.8m	8.5	8.4	8.2	8.1	7.9	7.8	7.6	7.4	7.3	7.2	7.0	24.0
26.0					7.7/25.4m	7.2	7.1	6.9	6.8	6.7	6.5	6.3	6.1	6.0	5.9	26.0
28.0						6.3	6.2	6.0	5.8	5.7	5.5	5.3	5.2	5.0	4.9	28.0
30.0							5.4	5.2	5.0	4.9	4.7	4.5	4.3	4.2	4.0	30.0
32.0							5.2/30.7m	4.5	4.3	4.2	4.0	3.8	3.6	3.5	3.3	32.0
34.0								4.1/33.3m	3.7	3.6	3.3	3.2	3.0	2.9	2.7	34.0
36.0									3.2	3.0	2.8	2.6	2.5	2.3	2.0	36.0
38.0										2.6	2.3	2.2				38.0
40.0										2.5/38.6m						40.0

※表中の太線で囲まれた部分は、ブーム等の強度によって定められた値です。

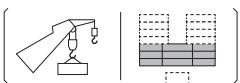

### ▶ 主ブーム定格総荷重表・サードドラム使用

(29.1tカウンタウエイト[オプション] / 1枚または2枚補助シーブ付き / ボールフック付き)

(単位：t)

作業半径 (m)	ブーム長さ (m)															作業半径 (m)
	15.2	18.3	21.3	24.4	27.4	30.5	33.5	36.6	39.6	42.7	45.7	48.8	51.8	54.9	57.9	
4.5	118.5															4.5
5.0	116.0	113.6/5.1m	93.5/5.6m													5.0
6.0	82.0	82.0	81.9	76.6/6.1m	65.9/6.7m											6.0
7.0	61.5	61.4	61.3	61.2	61.1	58.0/7.2m	50.9/7.7m									7.0
8.0	49.1	48.9	48.8	48.7	48.6	48.5	48.5	45.9/8.2m	41.1/8.8m							8.0
9.0	40.6	40.4	40.2	40.1	40.0	40.0	39.9	39.8	39.7	37.3/9.3m	34.2/9.8m					9.0
10.0	34.4	34.2	34.1	33.9	33.8	33.7	33.7	33.6	33.4	33.4	33.2	31.5/10.4m	28.5/10.9m	26.6/11.4m		10.0
12.0	26.0	25.8	25.7	25.5	25.4	25.3	25.2	25.1	25.0	24.9	24.7	24.6	24.5	24.4	24.7	12.0
14.0	20.7	20.5	20.3	20.1	19.9	19.9	19.8	19.6	19.5	19.4	19.2	19.1	19.0	18.9	18.7	14.0
16.0	19.1/14.9m	16.7	16.5	16.3	16.1	16.1	16.0	15.8	15.7	15.6	15.4	15.3	15.1	15.0	14.9	16.0
18.0		14.7/17.5m	13.7	13.6	13.4	13.3	13.2	13.0	12.9	12.8	12.6	12.4	12.3	12.2	12.0	18.0
20.0			11.6	11.4	11.2	11.1	11.0	10.9	10.7	10.6	10.4	10.3	10.1	10.0	9.9	20.0
22.0			11.6/20.1m	9.8	9.5	9.4	9.3	9.1	9.0	8.9	8.7	8.5	8.4	8.3	8.1	22.0
24.0				9.3/22.8m	8.2	8.1	7.9	7.8	7.6	7.5	7.3	7.1	7.0	6.9	6.7	24.0
26.0					7.4/25.4m	6.9	6.8	6.6	6.5	6.4	6.2	6.0	5.8	5.7	5.6	26.0
28.0						6.0	5.9	5.7	5.5	5.4	5.2	5.0	4.9	4.7	4.6	28.0
30.0							5.1	4.9	4.7	4.6	4.4	4.2	4.0	3.9	3.7	30.0
32.0							4.9/30.7m	4.2	4.0	3.9	3.7	3.5	3.3	3.2	3.0	32.0
34.0								3.8/33.3m	3.4	3.3	3.0	2.9	2.7	2.6	2.4	34.0
36.0									2.9	2.7	2.5	2.3	2.2	2.0		36.0
38.0										2.3	2.0					38.0
40.0										2.2/38.6m						40.0

※表中の太線で囲まれた部分は、ブーム等の強度によって定められた値です。

# アタッチメント(オプション)

## ▶ クラムシェル (59.1t カウンタウエイト)

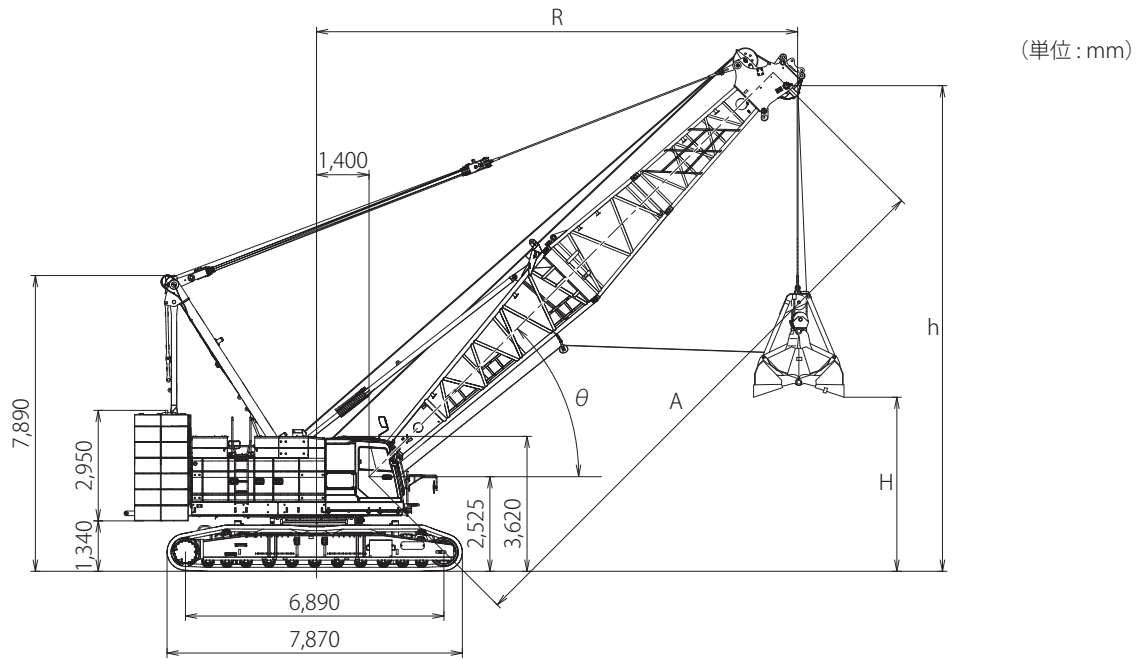

(単位: mm)

バケット 高さ 開口時	バケット 容量	2.0m <sup>3</sup>	T	3.9m
		2.5m <sup>3</sup>		4.3m
		3.0m <sup>3</sup>		4.5m
		4.0m <sup>3</sup>		4.7m

(10)	(11)
(8)	(9)
(6)	(7)
(4)	(5)
(3)	
(2)	
(1)	

カウンタウエイト

カーボディウエイト

カウンタウエイト	7段
カーボディウエイト	2個

〈注〉

- ① バケットの単体質量は7tを超えてはいけません。
- ② バケットと掘削物の合計質量が定格総荷重を超えてはいけません。
- ③ 掘削物に応じて、次式により最適なバケットをお選びください。  
バケット容量 (m<sup>3</sup>) × 掘削物比重 (t/m<sup>3</sup>) + バケット質量 (t) ≤ 定格総荷重 (t)  
掘削物: 砂、砂利、石灰石等 (見掛け比重 1 ~ 1.5 程度)
- 例) バケット容量 3.0m<sup>3</sup>、バケット質量 5.5t の場合  
(バケット容量) × (掘削物比重) + (バケット質量) ≤ (定格総荷重)  
3.0m<sup>3</sup> × 1.5 + 5.5t ≤ 10.0t
- ④ 作業サイクル、バケットの降下高さによってはバケット質量の低減が必要です。
- ⑤ 定格総荷重は安定度および強度から決まっています。旋回時にブーム横引き荷重が作用するような急加速・急減速は避けてください。特にブームが長いときは注意が必要です。
- ⑥ カウンタウエイト (59.1t)、カーボディウエイト (10.8t) を正しく装着し、ボルト、ナットで固定してください。

ブーム長さ	m	A	15.2					18.3					21.3					
ブーム角度	度	θ	38	48	58	66	70	39	48	56	64	70	40	48	55	62	68	
作業半径	m	R	14.0	12.0	10.0	8.0	7.0	16.0	14.0	12.0	10.0	8.0	18.0	16.0	14.0	12.0	10.0	
開口地上高さ m	バケット 容量	2.0m <sup>3</sup>	H	4.6	7.0	8.6	9.7	10.1	7.0	9.2	10.9	12.1	13.0	9.4	11.5	13.2	14.5	15.5
		2.5m <sup>3</sup>		4.2	6.6	8.2	9.3	9.7	6.6	8.8	10.5	11.7	12.6	9.0	11.1	12.8	14.1	15.1
		3.0m <sup>3</sup>		4.0	6.4	8.0	9.1	9.5	6.4	8.6	10.2	11.5	12.4	8.8	10.9	12.6	13.9	14.9
		4.0m <sup>3</sup>		3.8	6.2	7.8	8.9	9.3	6.2	8.4	10.0	11.3	12.2	8.6	10.7	12.4	13.7	14.7
ブームポイント高さ	m	h	13.3	15.6	17.2	18.5	19.0	13.3	15.6	17.2	18.5	19.0	15.7	17.9	19.5	20.8	21.8	
定格総荷重	t		12.5															

ブーム長さ	m	A	24.4					27.4						
ブーム角度	度	θ	42	48	54	60	65	42	48	54	59	64	68	
作業半径	m	R	20.0	18.0	16.0	14.0	12.0	22.0	20.0	18.0	16.0	14.0	12.0	
開口地上高さ m	バケット 容量	2.0m <sup>3</sup>	H	11.8	13.9	15.5	16.8	17.9	14.1	16.1	17.8	19.2	20.4	21.3
		2.5m <sup>3</sup>		11.4	13.5	15.1	16.4	17.5	13.7	15.7	17.4	18.8	20.0	20.9
		3.0m <sup>3</sup>		11.2	13.3	14.9	16.2	17.3	13.5	15.5	17.2	18.6	19.8	20.7
		4.0m <sup>3</sup>		11.0	13.1	14.7	16.0	17.1	13.3	15.3	17.0	18.4	19.6	20.5
ブームポイント高さ	m	h	18.1	20.2	21.8	23.2	24.3	20.4	22.5	24.1	25.5	26.6	27.5	
定格総荷重	t		12.5					10.0						



# 台船搭載(オプション)

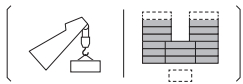

## 主ブーム定格総荷重表 (53.1tカウンタウエイト)

(単位: t)

作業半径 (m)	ブーム長さ (m)									作業半径 (m)
	15.2	18.3	21.3	24.4	27.4	30.5	33.5	36.6	39.6	
5.0	80.0/5.3m									5.0
6.0	68.9	66.6	62.8/6.7m							6.0
7.0	60.5	60.2	59.9	56.4/7.4m						7.0
8.0	52.5	52.2	51.9	51.7	51.0/8.1m	46.5/8.7m				8.0
9.0	46.3	46.1	45.8	45.6	45.3	45.2	41.4/9.4m			9.0
10.0	41.4	41.1	40.8	40.7	40.4	40.2	40.1	37.3/10.1m	33.3/10.8m	10.0
12.0	34.0	33.7	33.4	33.2	33.0	32.8	32.7	32.4	32.0	12.0
14.0	24.8	28.2	28.2	28.0	27.7	27.5	27.3	27.1	26.9	14.0
16.0	21.1/14.9m	22.4	23.6	24.0	23.7	23.6	23.4	23.1	22.9	16.0
18.0		17.5/17.5m	19.2	20.0	20.5	20.5	20.3	20.1	19.9	18.0
20.0			14.9	16.5	17.0	18.0	17.6	17.4	17.3	20.0
22.0			14.6/20.1m	13.8	14.3	15.1	15.5	15.2	15.1	22.0
24.0				12.3/22.8m	12.0	12.9	13.6	13.5	13.4	24.0
26.0					10.3/25.4m	11.0	11.7	12.0	11.9	26.0
28.0						9.3	10.1	10.5	10.7	28.0
30.0							8.6	9.2	9.6	30.0
32.0							8.2/30.7m	8.0	8.4	32.0
34.0								7.2/33.3m	7.3	34.0
36.0									6.4	36.0

〈注〉

- 作業半径とはクレーンの旋回中心よりつり上荷重の重心までの水平距離を意味します。
- 定格総荷重は、フックブロック、玉掛用ワイヤロープ等のつり具の質量を含んだ値です。
- 作業時のクレーン部の傾斜角度は、水平面に対してクレーン前後方向で3°以内、クレーン左右方向で1.5°以内となるようにしてください。定格総荷重はこの条件において設定しています。
- 上表能力はクローラを固縛した時の能力です。
- 表内の定格総荷重は強度域です。
- 主巻ロープの巻掛数に対する最大巻上定格総荷重は下記の通りです。

巻掛数 (本)	2	3	4	5	6	7
最大巻上定格総荷重 (t)	25.0	37.5	50.0	62.5	75.0	80.0

- カウンタウエイト (53.1t) を正しく装着し、ボルト・ナットで固定してください。
- 主ブームに補助シーブを取り付けたままで主フックを使用する場合の定格総荷重は、主ブーム定格総荷重から、1.2tまたは1.5tを差し引いた値となります。  
1.2t: 補助シーブ 1枚仕様または2枚仕様とスィベル付軽量フックを考慮した値  
1.5t: 補助シーブ 1枚仕様または2枚仕様とボールフックを考慮した値  
ただし最小定格総荷重は2.0tとします。

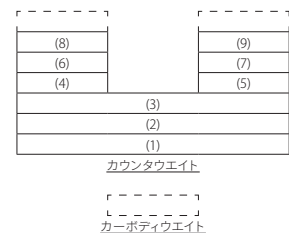
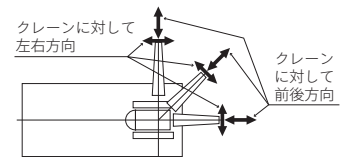

## コラムシェル作業定格総荷重表 (53.1tカウンタウエイト)

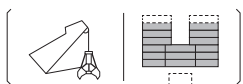

(単位: t)

作業半径 (m)	ブーム長さ (m)					作業半径 (m)
	15.2	18.3	21.3	24.4	27.4	
8.0	12.5					8.0
9.0	12.5	12.5				9.0
10.0	12.5	12.5	12.5			10.0
12.0	12.5	12.5	12.5	11.5	9.0	12.0
14.0	12.5	12.5	12.5	11.5	9.0	14.0
16.0		12.5	12.5	11.5	9.0	16.0
18.0			12.5	11.5	9.0	18.0
20.0				11.5	9.0	20.0
22.0					9.0	22.0

〈注〉

- バケットの単体質量は7tを超えてはいけません。
- バケットと掘削物の合計質量が定格総荷重を超えてはいけません。
- 作業半径とは荷重状態におけるクレーンの旋回中心よりバケット重心までの水平距離を意味します。
- 旋回時にブーム横引き荷重が作用するような急加速・急減速運転、旋回投げ捨ておよび斜め引き掘削等を行わないでください。
- 作業時のクレーン部の傾斜角度は、水平面に対してクレーン前後方向で3°以内、クレーン左右方向で1.5°以内となるようにしてください。定格総荷重はこの条件において設定しています。
- 上表能力はクローラを固縛した時の能力です。
- カウンタウエイト (53.1t) を正しく装着し、ボルト・ナットで固定してください。

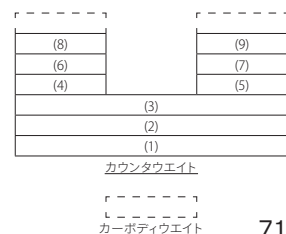
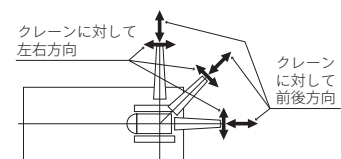

## ▶ 分解時の寸法・質量

- 記載の数値は参考値です。
- 一般公道での輸送に際しては関係法規を遵守してください。

## ■ 本体

名称	寸法 mm	質量 kg
輸送姿勢 ・ ガントリ ・ 下部ブーム ・ サードドラム ・ ブームドラム ・ クレーンバックストップ ・ ワイヤロープ (主巻、補巻、サード、ブーム起伏) 付 ・ ステップなし ・ トランスリフタ		39,300
輸送姿勢 ・ ガントリ ・ 下部ブームなし ・ サードドラム ・ ブームドラム ・ クレーンバックストップなし ・ ワイヤロープ (主巻、補巻、サード) 付 ・ ステップなし ・ トランスリフタ		34,600
輸送姿勢 ・ ガントリなし ・ 下部ブームなし ・ サードドラム ・ ブームドラム ・ クレーンバックストップなし ・ ワイヤロープなし (主巻、補巻、サード、ブーム起伏) ・ ステップなし ・ トランスリフタなし		28,800

※ 1 キャブ側にステップがある場合：3,170  
両側にステップがある場合：3,340

▼ 下部本体

名称	寸法 mm	質量 kg
クローラ		14,600
トランスリフタ (4個)		265/1個

▼ カウンタウエイト

名称	個数		寸法 mm	質量 kg
	標準	減トン		
カウンタウエイト (1)	1	1		9,800
カウンタウエイト (2)	1	1		9,610
カウンタウエイト (3)	1	1		9,700

名称	個数		寸法 mm	質量 kg
	標準	減トン		
カウンタウエイト (4)、(6)、(8) (L)	3	3		4,000
カウンタウエイト (5)、(7)、(9) (R)	3	3		4,000
カウンタウエイト (10) (L)	1	0		3,000
カウンタウエイト (11) (R)	1	0		3,000
カーボディウエイト (2個)	2	0		5,400/1個

■ アタッチメント (ガイドラインの質量は含まれていません)

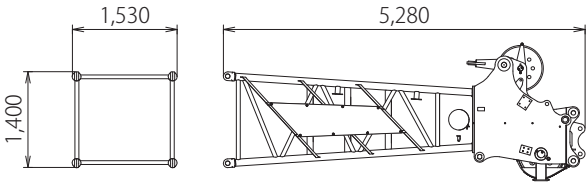
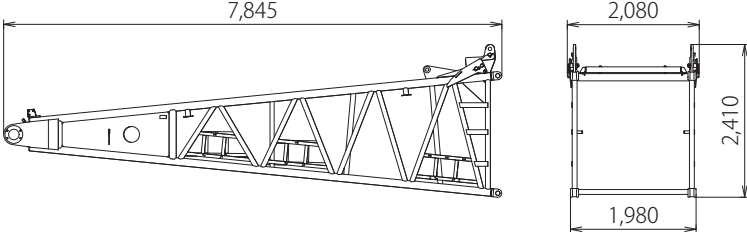
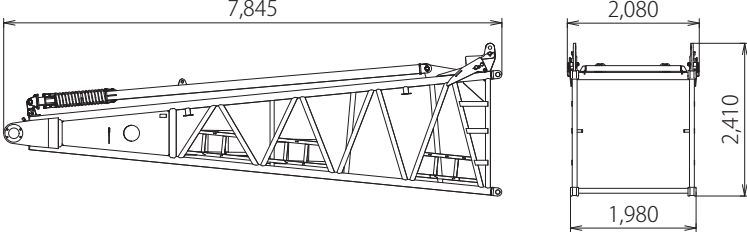
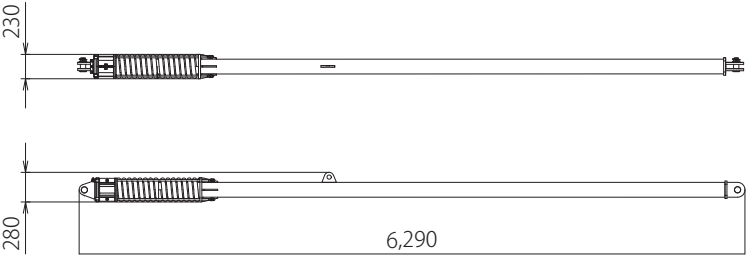
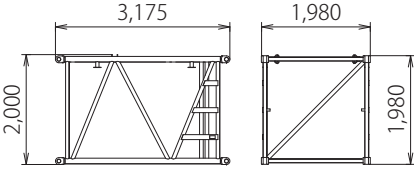
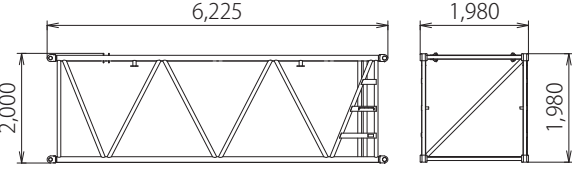
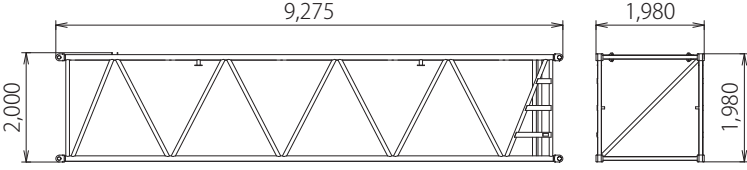
名称	寸法 mm	質量 kg
上部ブーム		2,160
下部ブーム		2,825
強化バックストップ付 下部ブーム		3,695
強化バックストップ (2 個)		435 / 1 個
3.0 m 中間ブーム		530
6.1 m 中間ブーム		850
9.1 m 中間ブーム		1,160

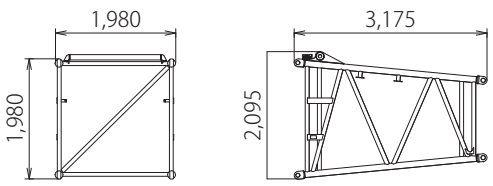
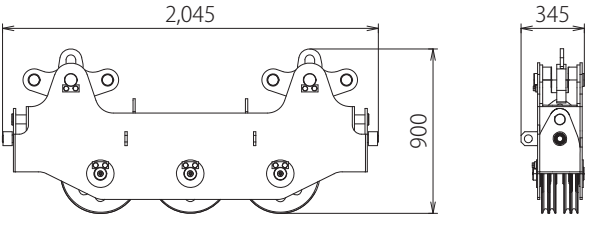
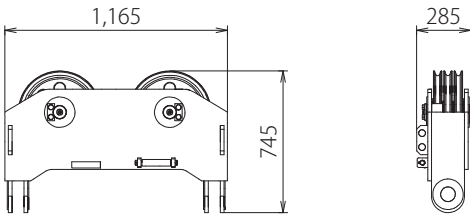
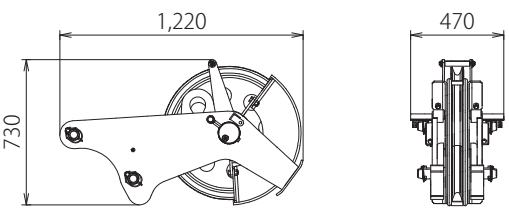
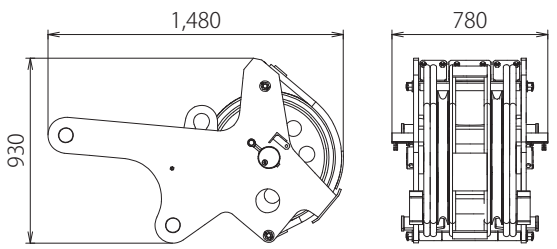
名称	寸法 mm	質量 kg
中間テーパーブーム		550
クレーン用上部スプレッダ		475
クレーン用下部スプレッダ		300
補助シーブ (1枚仕様) (φ 30mm ワイヤロープ用)		290
補助シーブ (2枚仕様) (φ 30mm ワイヤロープ用)		570

名称	寸法 mm	質量 kg
120t フック (φ 30mm ワイヤロープ用)		1,800
70t フック (両カギ) (φ 30mm ワイヤロープ用)		1,200
70t フック (片カギ) (φ 30mm ワイヤロープ用)		930
50t フック (φ 30mm ワイヤロープ用)		850

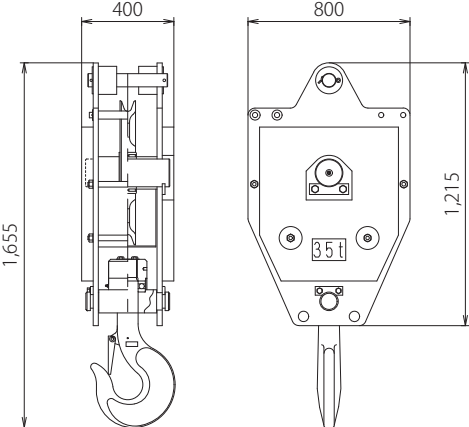
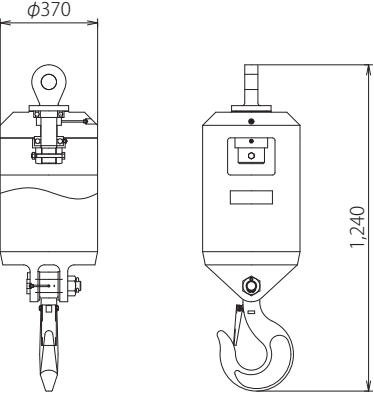
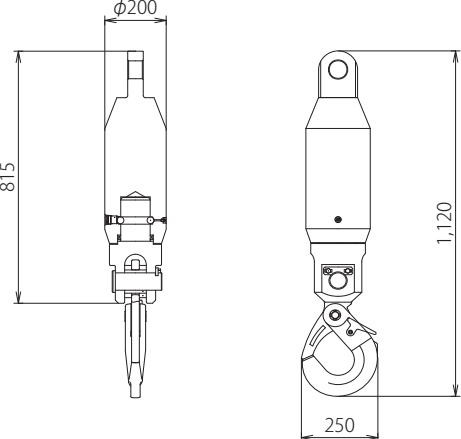
名称	寸法 mm	質量 kg
35t フック (φ 30mm ワイヤロープ用)		700
15.5t ボールフック (φ 30mm ワイヤロープ用)		460
15.5t 軽量フック (φ 30mm ワイヤロープ用)		145



## ▶ 標準装備品

●上下部本体
ウインチ (φ30 フリーフォール付、主巻／補巻)
カウンタウエイト 59.1t
カーボディウエイト 10.8t
910mm 幅シュー
136AH/5HR バッテリー
トランスリフタ
ガントリ起伏シリンダ
アクセルグリップ
ブームドラム速度調整トリマ
主巻・補巻ドラム速度調整トリマ
旋回中立フリー／ブレーキ切替システム
運転席サイドデッキ
右ガード梯子
左ガード昇降ステップ
クローラ昇降ステップ
アンチスリップシート (ガード上面)
上部スプレッド自動格納装置
標準工具一式
前照灯×2
バックミラー×2
ドラムミラー
ワンウェイコール
水準器 (カーボディ)
ブームコネクタピンホルダ
●運転室
エアコン
カップキーパ
バインダホルダ
スマートフォンホルダ

ラジオ (FM/AM)
シガーライタ (24V)
USB 電源 (5V × 1)
間欠式ワイパ&ウインドウウォッシャ (天窗／前面)
サンバイザ
天井ブラインド
グリーンガラス
フロアマット (布製)
靴置きトレイ
●安全装置
過負荷防止装置 (ブーム巻下緩停止機能付)
過負荷防止装置解除防止キー
過巻防止装置解除防止キー
メインモニタ
第2過巻防止装置 (ブーム角度極限停止機能)
ブーム過巻自動停止装置 (緩停止機能付)
フック過巻自動停止装置
ブームバックストップ
乗降遮断式レバーロック
操作レバーロック (走行／主巻／補巻／ブーム起伏)
ケーブル式ドラムパウル (主巻／補巻／ブーム起伏)
中立時ネガブレーキ (主巻／補巻／ブーム起伏／走行)
旋回中立フリー／ブレーキ切替表示灯
旋回中立フリー／ブレーキ切替スイッチ
油圧安全弁 (主巻／補巻／ブーム起伏／走行)
ホーン
旋回ブレーキロック
旋回ロック
旋回フラッシュ／ブザー

## ▶ オプション装備品

トラベルキット
カウンタウエイト・クローラつりワイヤロープ
サードドラム (φ26 フリーフォール付)
リービングウインチ (ワイヤロープφ8)
油圧式タグライン
補助シーブ
ガイケーブル格納ブラケット
減トン仕様 (カウンタウエイト枚数検出装置付)
台船搭載用 ML
フットアクセル
ブーム起伏ペダル
揚程・深度表示装置
ドラム回転感知レバー
本体傾斜計
旋回制限装置
水準器 (キャブ内)
キャブ天井ガード
サイドキャットウォーク (手すり付)
左右ガード上面手すり
カウンタウエイト上面手すり
定格総荷重表銘板 (下部ブーム腹面)
後方監視カメラ
左方監視カメラ
主補ドラム監視カメラ
ブームドラム監視カメラ

ドラムライト
過負荷外部表示灯 (角型3色灯)
風速計
航空障害灯
中立フリー／過負荷ボイスアラーム
走行／旋回ボイスアラーム
電動式燃料給油ポンプ
消火器
扇風機
基礎 (ハンマグラブ) 専用モード
後方作業灯
防塵ネット (右ガード後部)
キャブ前方追加ライト (キャブ左上部)
寒冷地対策オプション
主補コントロールレバー入替
油圧式ブームフットピン
上部ブーム腹面保護材
中間ブーム梯子
ブームつり用ナイロンスリング
ワイヤ脱落防止ガイド
ブーム上面足場 (鉄/アルミ)
ブーム上面手摺 (一本物/親綱式)
ブームつりピース
別置工具箱
独立合流切り替え機能

A series of horizontal dashed lines for writing.

Handwriting practice lines consisting of 28 horizontal dashed lines.

- つり上げ荷重5t以上の移動式クレーン運転には「移動式クレーン運転士免許証」、クラムシェル作業には「車両系建設機械(整地ほか)運転技能講習修了証」、基礎工事には「車両系建設機械(基礎用)運転技能講習修了証」がそれぞれ必要です。
- 本カタログで使用される標章「KOBELCO」は、株式会社神戸製鋼所の登録商標です。

## コベルコ建機株式会社

[www.kobelco-kenki.co.jp](http://www.kobelco-kenki.co.jp)

東京本社 / 〒141-8626 東京都品川区北品川5-5-15 Tel:03-5789-2111

### ■ クレーンの販売・サービス拠点

北海道 Tel:011-788-2382 / 東北 Tel:0223-24-1482  
関東 Tel:045-834-9992 / 北陸 Tel:076-274-1218  
東海 Tel:052-603-1205 / 近畿 Tel:06-6414-2103  
中四国 Tel:082-810-3880 / 九州 Tel:092-410-3035

■ お問い合わせは・・・